

# 86-95 Low Range Off Road Universal Front Shock Tower Kit for Suzuki Samurai (SKU# SSP-UST)

Revised 10/29/13

## Installation Instructions



**CAUTION:** Safety glasses should be worn at all times when working with vehicles and related tools and equipment.



### Suggested Tools:

- Twin Post lift (or Floor Jack and Safety Stands)
- 4" Angle Grinder
- Metal cutting tool(s)
  - Option 1 - Plasma Arc Cutter.
  - Option 2 - Oxy-Acetylene Torch
  - Option 3 - Sawzall® with metal cutting blade
  - Option 4 - Angle Grinder with cut-off blade
- Box End Wrenches 14, 17, & 19 mm
- Open End Wrenches 14 mm
- Sockets 17 & 19 mm
- Adjustable End Wrench (Crescent Wrench)
- Felt Tipped Marker
- Pall Peen Hammer
- Cold Chisel

## Lifting and Supporting the Vehicle



### Lifting Option 1

Lift and support the vehicle on a twin post, frame contact, lift.

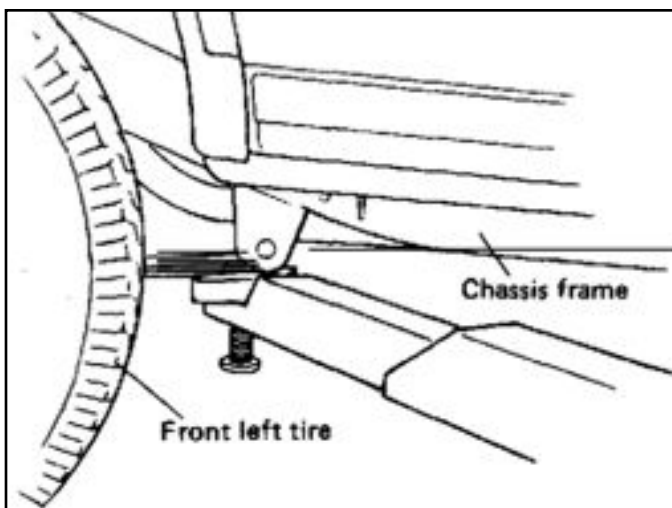

Front Positioning

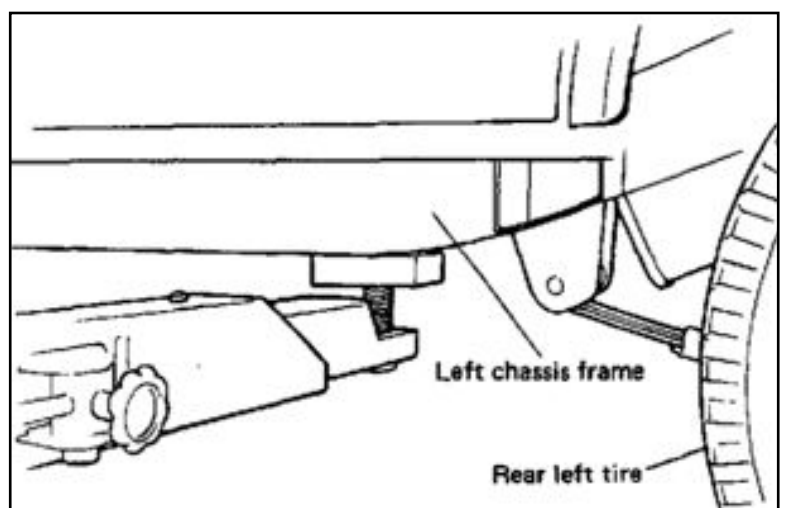

Rear Positioning

## Lifting Option 2

Lift the front of the vehicle with a floor jack and support it on safety stands.

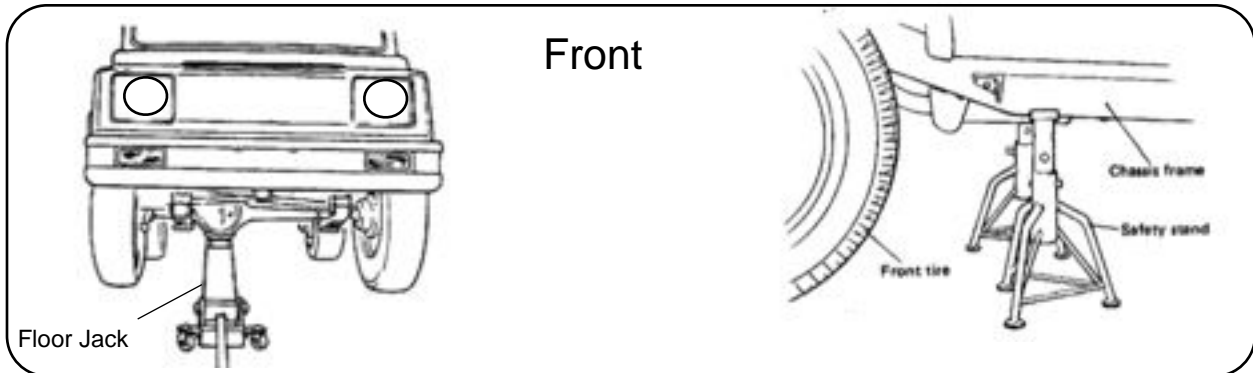

## Beginning on the Driver Side Front Wheel



### Step 1

Remove the driver side front wheel.

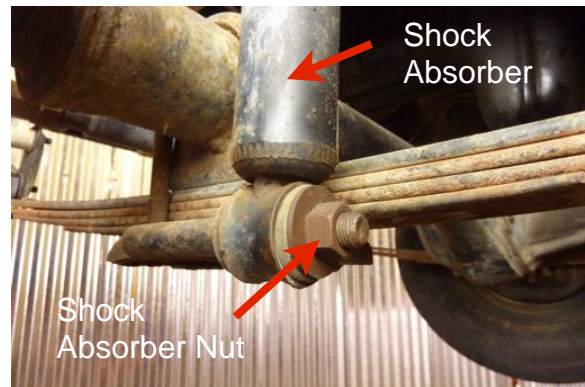

### Step 2

Remove the lower shock absorber nut and washer with a 17 MM socket.

Note: Do not disconnect the lower shock absorber yet.



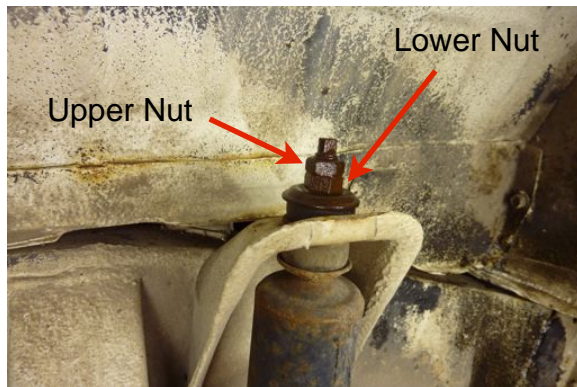

### Step 3

Begin disconnecting the upper end of the shock absorber by removing the upper nut.



### Step 4

This is done by holding the lower nut with a 14 mm open end wrench and turning the upper nut with a 14 mm socket and ratchet.



### Step 5

Then hold the shaft with an adjustable end (or Crescent) wrench and remove the lower nut with an open end wrench (or a ratcheting box end wrench).



### Step 6

Remove the washer and rubber bushing. Push the top of the shock absorber down and out of the upper shock mount. Then slide the shock off the bottom mount and set the shock absorber aside.



Bump Stop



## Step 7

Remove the bump stop by removing (2) bolts with a 12 mm socket.

## Step 8

Cut off the upper shock mount.

Note: We chose to use a plasma arc cutting machine, but you could use a sawzall®, angle grinder with a cut off blade, an oxy-acetylene torch or any combination of these tools. Some have even used a hammer and chisel as part of the removal process.

Plasma Cutter

Sawzall®



Angle Grinder

Oxy-Acetylene Torch



## Caution:

All of these methods of metal cutting involve potential dangers. Be sure to follow all manufacturer safety rules and guidelines, which includes (but is not limited to) the wearing of protective clothing and safety equipment such as gloves, welding hood, face shield, and safety glasses.





## Caution

When cutting components from the frame it is important not to cut **INTO** the frame. Cutting into the frame can cause the frame to fatigue and break which could result in loss of vehicle stability and control resulting in serious accident and or bodily injury. We recommend that a trained professional perform this aspect of the job.

Note: If by accident you do cut into the frame, be sure to weld up or reinforce the affected area before installing the new shock mount.



## Step 9

Cut off the bump stop mount.

Back Panel of Shock Mount

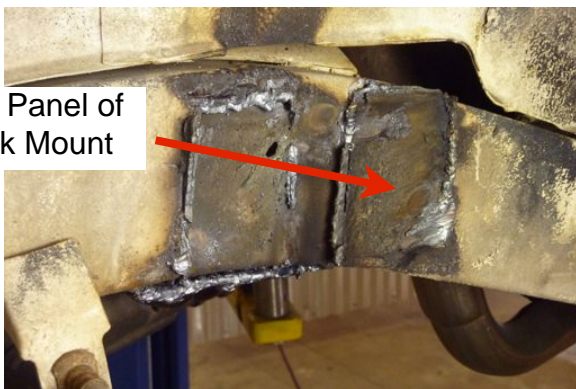

## Tech Tip 9

This is a view of the frame after most of the upper shock mount and bump stop mount has been cut away from the frame.

Notice the back panel of the shock mount still remains.



## Step 10

Carefully grind away any remaining weld from the shock mount area. This is done so that the back side of the shock mount can be removed. See next picture.





## Step 11

Peel away the back side of the shock mount from the frame.

Note: It may be necessary to use a hammer and chisel to assist in removing this piece of metal.



## Step 12

Grind away any excess metal and undercoating material that remains.

**Caution:** Be sure **NOT** to grind away any more of the frame metal than is absolutely necessary to make a clean flat, weldable surface. The frame is thin metal and can be weakened if you grind away too much metal.



## Tech Tip 12 A

We had a few minor “burn-throughs”. If this happens to you, be sure to weld them up before installing the shock mount.



## Tech Tip 12 B

This picture shows what the frame should look like before installing the shock mount. It should be clean, smooth and free of undercoating.

Note: It appears as though the frame is blue, which could indicate excessive heat from cutting, grinding or welding. However this is only a reflection in the polished metal. See photograph in Step 23 for a clearer view.



Inner Fender



### Step 13

It may be necessary to bend the inner fender back toward the engine, in the area shown, to make room for the shock mount.

### Step 14

Temporarily install the lower end of the shock absorber to the lower mount. Leave the nut and washer off for now.

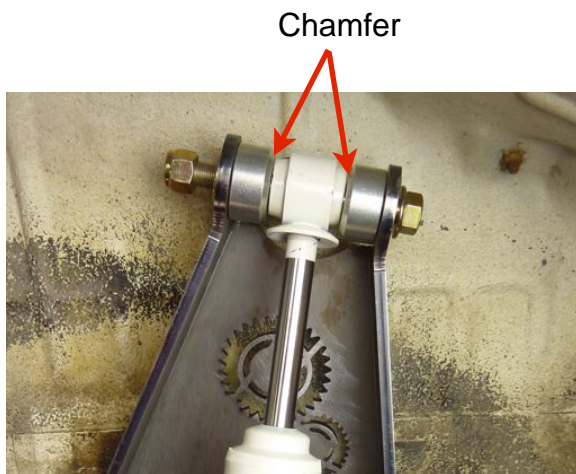

Chamfer

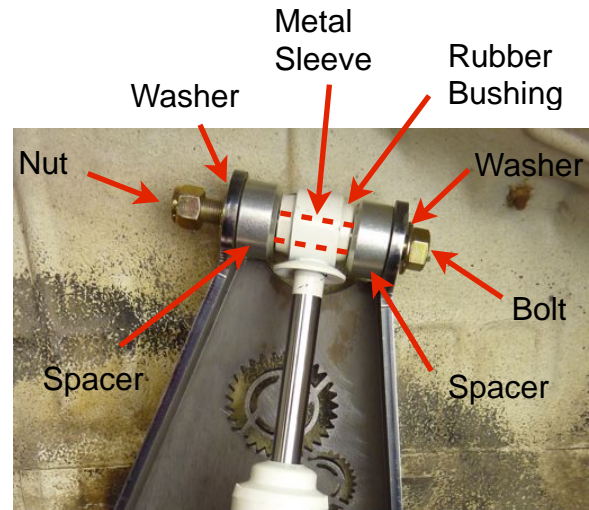

Metal Sleeve

Rubber Bushing

Washer

Nut

Washer

Bolt

Spacer

Spacer

### Step 15

Temporarily install the upper end of the shock absorber in the shock tower. Just leave the nut and bolt loose for now.

Note: The chamfered side of the spacers go inward.

### Tech Tip 15

Proper location of hardware on upper shock absorber.

Note: There is a metal sleeve that goes inside the rubber bushing.







## Step 16

Position the shock tower as shown.

Note: The placement of the shock tower will depend on your suspension type, axle type, and lower shock mount location. All of these features will vary from vehicle to vehicle. Simply put: "use your best judgement."

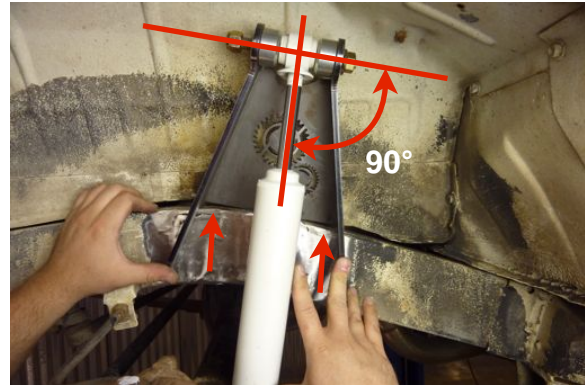

## Tech Tip 16 A

There should be about the same gap between the frame and the shock tower on both locations indicated by the red arrows; and the shock should be at about a 90° angle with the upper mounting bolt.



## Tech Tip 16 B

In some applications there may be a larger opening at the rear of the shock tower. To fill this gap, we have included a wedge shaped shim that can be inserted and welded. These shims are optional. We believe the shock tower is secure enough without it. But, some folks like the added strength and appearance.



*This shows the wedge in place on a PASSENGER side shock tower.*

## Tech Tip 16 C

Tack weld the wedge in place if being used.



### Step 17

Once positioned properly, mark the frame indicating the front location of the shock tower with a felt tipped marker.

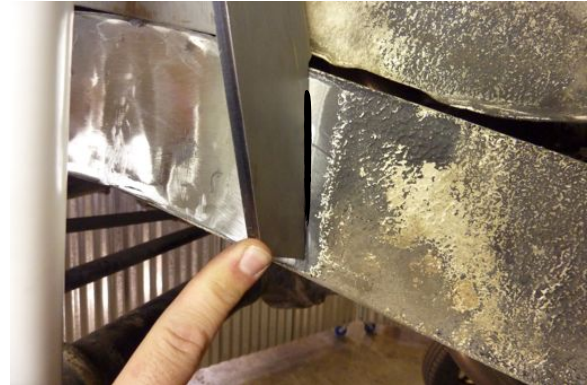

### Step 18

Mark the frame indicating the rear location of the shock tower in the same manner.

### Step 19

Remove the shock absorber and shock tower in preparation for the next step.

### Tech Tip 19 A

Since the backside of the shock tower will be inaccessible after installation, we recommend you paint the backside before installation. This is to inhibit rust and improve appearance.

Note: We do not recommend painting the entire shock tower at this point, although you could paint most of it. Simply leave the area that will need to be welded, "paint free" for now.







## Step 20

After the paint dries, reposition the shock tower and tack weld the front of the tower to the frame as shown.



## Step 21

Then tack weld the rear of the tower.



*Passenger Side Shock Tower*

## Tech Tip 21

Tech weld the wedge in place if being used.



## Step 22

Temporarily reinstall the shock absorber to make sure everything fits well. If everything fits well, remove the shock absorber and continue to the next step. If it does not fit well, break the tack welds and repeat Steps 16 and 21.



### Step 23

Weld the shock tower in the three areas shown.



*Passenger Side Shock Tower*

### Tech Tip 23

Weld in the wedge if being used.



### Step 24

Paint all exposed metal to inhibit rust and improve appearance.

### Rubber Bushing

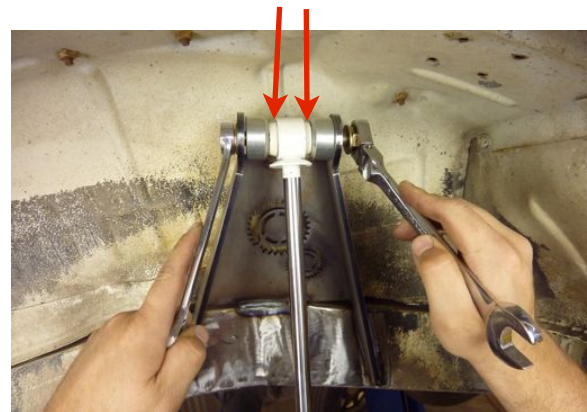

### Step 25

Reinstall the shock absorber using the supplied hardware as shown in Step 15. Tighten the hardware by hold the bolt with a 17 mm box end wrench and tightening the nut with a 19 mm ratcheting box end wrench. Torque the nut to 50 ft. Lbs.





Congratulations! You have successfully installed an upper shock mount. We hope these instructions have been helpful. If you have questions, please call Technical Support by dialing the number listed at the bottom of the page.



As always, If you experience any difficulty during the installation of this product or any other Low Range Off-Road product, please contact Low Range Off-Road Technical Support at 801-805-6644 M-F 7:30 am to 5:30 pm MST. Thank you for purchasing from Low Range Off-Road.



These instructions are designed as a general installation guide. Installation of many Low Range Off-Road products require specialized skills such as metal fabrication, welding and mechanical trouble shooting. If you have any questions or are unsure about how to proceed, please contact our shop at 801-805-6644 or seek help from a competent fabricator. Using fabrication tools such as welders, torches and grinders can cause serious bodily harm and death. Please operate equipment carefully and observe proper safety procedures.

Rock crawling and off-road driving are inherently dangerous activities. Some modifications will adversely affect the on-road handling characteristics of your vehicle. All products sold by Low Range Off-Road are sold for off road use only. Any other use or application is the responsibility of the purchaser and/or user. Some modifications and installation of certain aftermarket parts may under certain circumstances void your original dealer warranty. Modification of your vehicle may create dangerous conditions, which could cause roll-overs resulting in serious bodily injury or death. Buyers and users of these products hereby expressly assume all risks associated with any such modifications and use.

Revised 10/28/13© Copyright 2013 Low Range Off-Road, LC All Rights Reserved

