



86-95 Suzuki Samurai Samurai Front Axle Knuckle Rebuild Kits (SKU# SAX-KRK)

Revised 6-6-14

Installation Instructions



CAUTION: Safety glasses should be worn at all times when working with vehicles and related tools and equipment.



FOR ADDITIONAL COPIES OF THESE AND OTHER INSTRUCTIONS GO TO:
www.lowrangeoffroad.com and click on the "TECH AND INSTRUCTIONS" tab.

Suggested Tools:

- Twin Post Lift (or floor jack and jack stands)
- 19 mm lug wrench
- 2-8X1.25X25mm bolts
- Large Standard Screwdriver
- Sockets: 10,12,14 & 17
- Ratchet
- Ball Peen Hammer - Medium
- C-Clamp
- Snap Ring Pliers
- Diagonal Cutting Pliers
- Cold Chisel - Small
- Gasket Scraper
- Torque Wrench - Foot-Pound
- Torque Wrench - Inch-Pound (Needle or Gauge Type)
- Seal Puller
- Drift Punch 3/16"
- Brass Hammer
- Wheel Bearing Grease (High Temperature)
- Pull Scale 0-10 pound
- Brake Cleaner - Aerosol Can



Tech Tip

When working on suspension, brakes or drive train parts it is a good idea to spray all fasteners with penetrating oil a day ahead. If not done a day ahead, an hour or even minutes before is helpful.

Step 1

Lift and support the vehicle on a twin post lift.

Note: We used a twin post lift, but this job could easily be done with a floor jack and (2) safety stands.

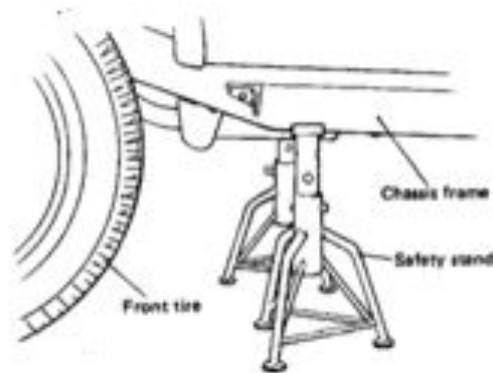
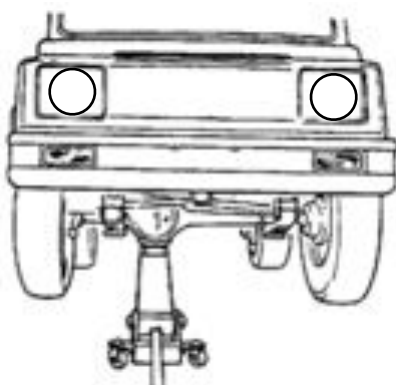

Tech Tip

Proper positioning of floor jack.

Tech Tip

Proper positioning of safety stands.



Disc Brake Assembly Parts

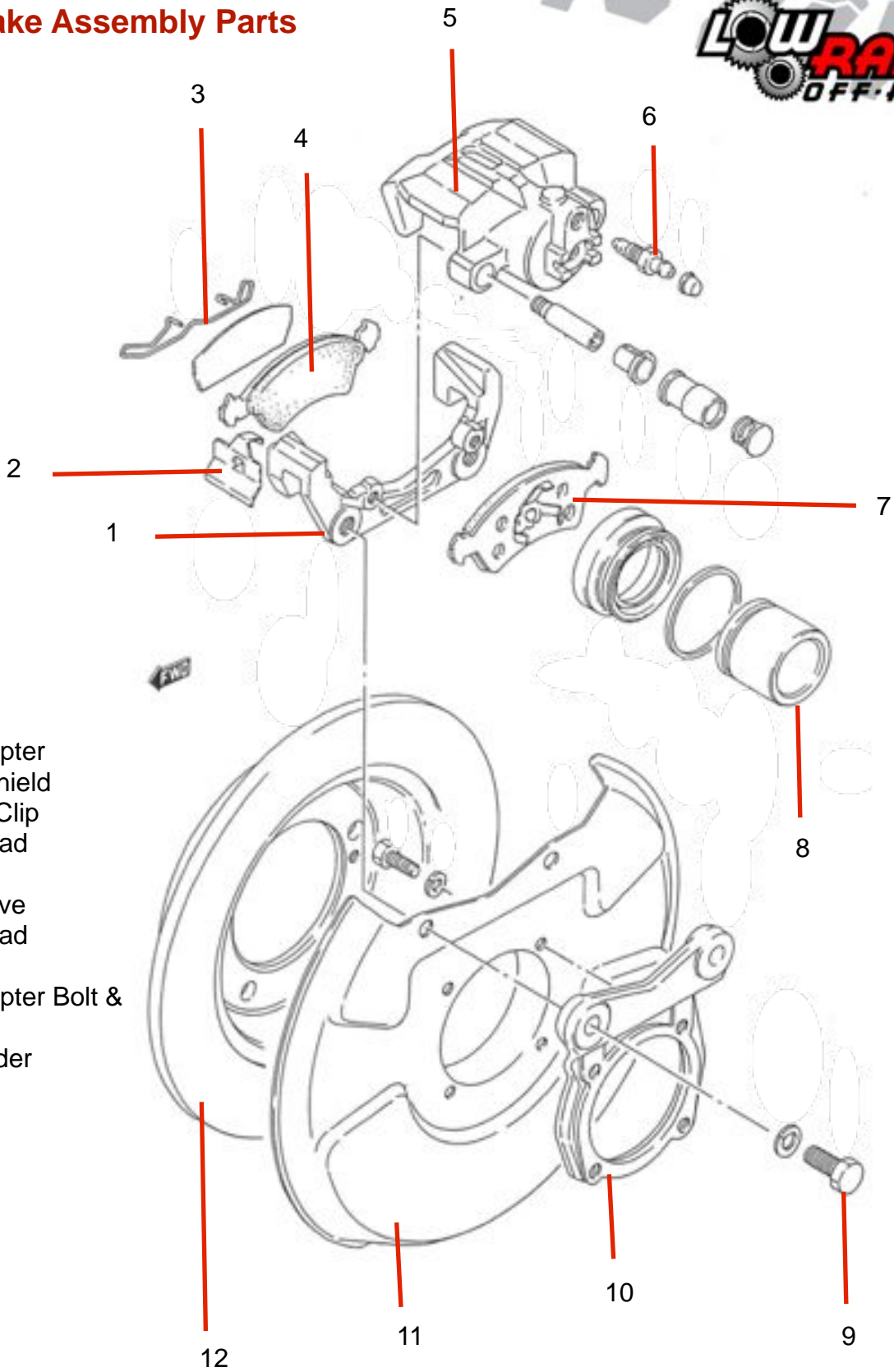

1. Caliper Adapter
2. Protector Shield
3. Anti-Rattle Clip
4. Outboard Pad
5. Caliper
6. Bleeder Valve
7. Outboard Pad
8. Piston
9. Caliper Adapter Bolt & Washer
10. Caliper Holder
11. Dust Cover
12. Disc

Removing the Disc Brake Components



Step 2

Remove the passenger side front wheel assembly by removing the (5) lug nuts using a 19 mm socket.



Step 3

Position a C-Clamp on the outboard brake pad and the brake line banjo bolt as shown. Press the outboard brake pad inward about 1/8".

Note: This will make it easier to remove and replace the disc brake assembly.



Step 4

Remove the (2) caliper adapter bolts using a 17 mm socket.



Step 5

Remove the caliper and caliper adapter by lifting upward.

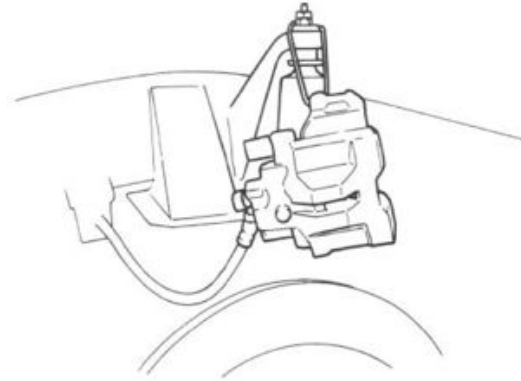

Step 6

Rest the caliper assembly on the leaf spring or suspend it using a wire.

Caution: Never let a caliper hang by the brake hose. The hose can be weakened or damaged.

Tech Tip

Illustration of suspending a brake caliper.



Step 7

Begin removing the disc by installing two 8X1.25X25mm bolts in the rotor as shown.



Step 8

Then tighten these bolts (alternating back and forth) using a 12 mm socket. Tightening these bolts should press the disc away from the hub. If the disc does NOT come loose, continue to the next step. If the disc does come loose, skip the next step.





Step 9

Strike the disc with a ball peen hammer in several locations around the disc as shown. If the disc does not come loose, tighten the bolts a little more and strike the disc with the hammer again. Continue alternating between striking and tightening until the disc comes free.

Caution: Be careful not to damage the wheel studs.



Step 10

Remove the disc and set it aside.

Disconnecting the Tie Rod



Step 11

Begin removing the cotter pin by straightening the legs with diagonal cutting pliers.

Step 12

Remove the cotter pin using the same pliers.





Step 13

Loosen the castle nut using a 17 mm socket.

Note: Leave the nut in place to protect the threads of the tie rod end stud.



Step 14

Strike the steering arm using a ball peen hammer.

Note: Don't be shy. Hit it hard. It may take several blows, but it will come out.



Step 15

Once the tie rod end stud comes loose, remove the castle nut, disconnect the tie rod and move the tie rod out of the way.

Axle & Knuckle Parts

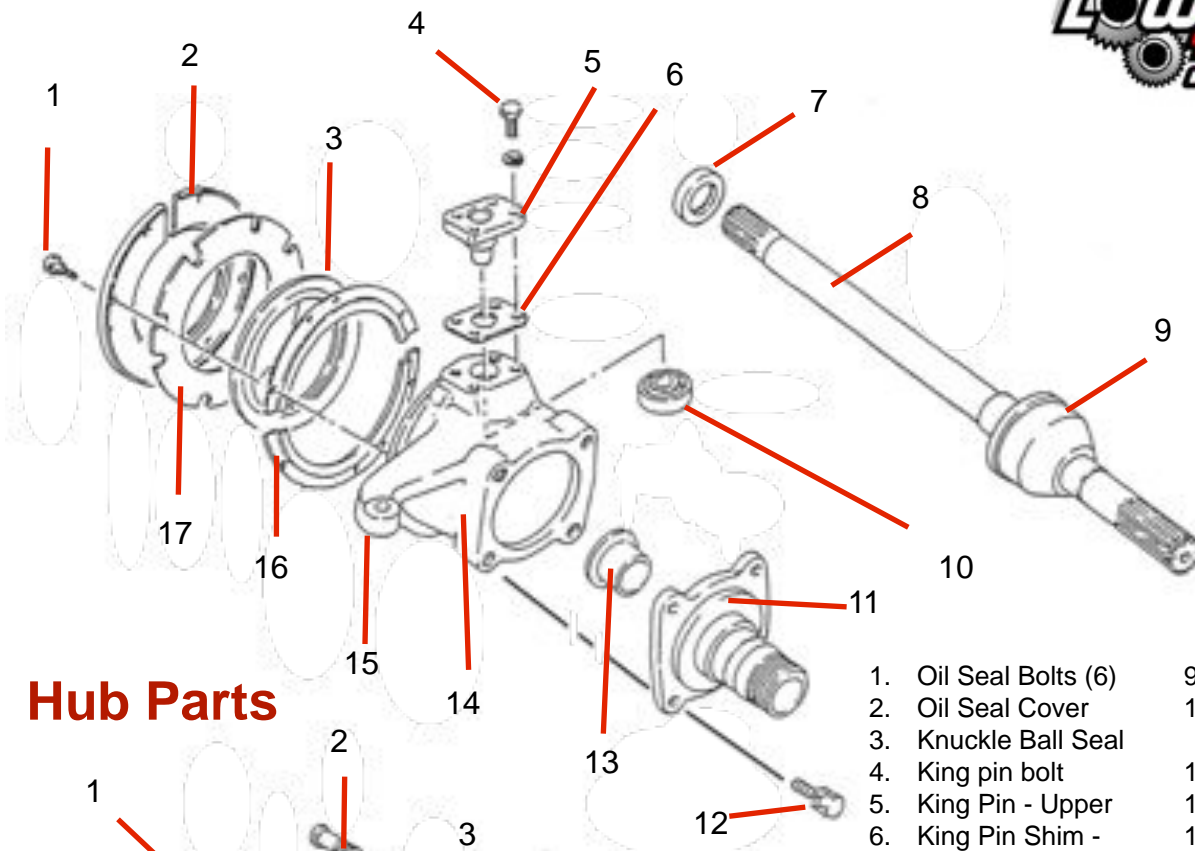

Hub Parts

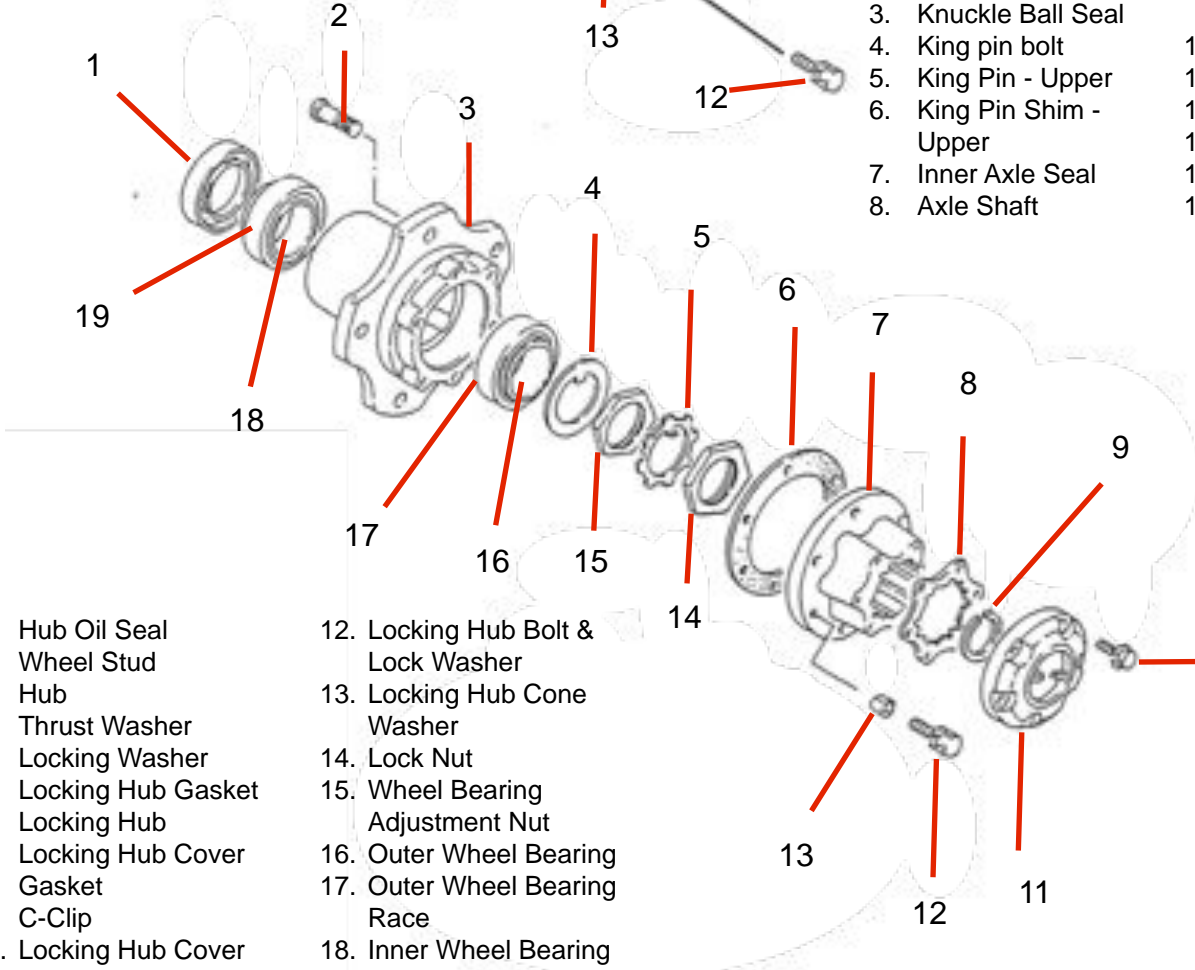

- | | |
|--------------------------|-------------------------------------|
| 1. Oil Seal Bolts (6) | 9. Birfield Joint |
| 2. Oil Seal Cover | 10. King Pin Bearing & Race - Upper |
| 3. Knuckle Ball Seal | 11. Spindle |
| 4. King pin bolt | 12. Spindle Bolt |
| 5. King Pin - Upper | 13. Axle Bushing |
| 6. King Pin Shim - Upper | 14. Steering Knuckle |
| 7. Inner Axle Seal | 15. Steering Arm |
| 8. Axle Shaft | 16. Seal Retainer Rings |

- | | |
|-----------------------------|------------------------------------|
| 1. Hub Oil Seal | 12. Locking Hub Bolt & Lock Washer |
| 2. Wheel Stud | 13. Locking Hub Cone Washer |
| 3. Hub | 14. Lock Nut |
| 4. Thrust Washer | 15. Wheel Bearing Adjustment Nut |
| 5. Locking Washer | 16. Outer Wheel Bearing |
| 6. Locking Hub Gasket | 17. Outer Wheel Bearing Race |
| 7. Locking Hub | 18. Inner Wheel Bearing |
| 8. Locking Hub Cover Gasket | 19. Inner Wheel Bearing Race |
| 9. C-Clip | |
| 10. Locking Hub Cover Bolt | |
| 11. Locking Hub Cover | |

Removing the Hub Assembly



Step 16

Remove the locking hub cover by removing the (6) bolts using a 10 mm socket.

Step 16 Continued

Locking hub cover removed.



Step 17

Remove the C-Clip using snap ring pliers.

Step 18

Remove the locking hub by holding the wheel studs with a large standard screwdriver and removing the (6) locking hub bolts using 12 mm socket.

Caution: Do not damage the threads of the wheel studs.





Step 18 Continued

Each bolt will have a washer and a cone washer.



Step 19

Once the bolts are removed, it may be necessary to tap the locking hub with a hammer to jar it loose.

Note: This should not take much force. Tap gently.

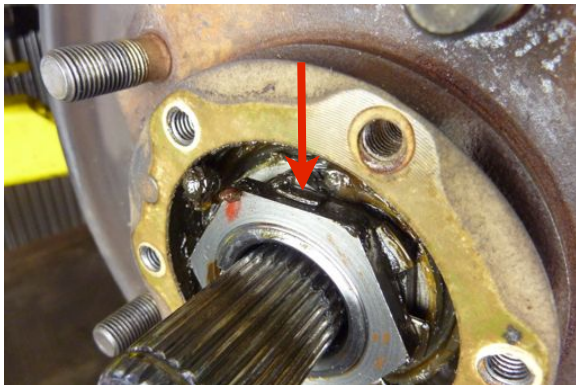

Step 20

Begin removing the wheel bearing lock nut by straightening the lock washer tabs using a small cold chisel or punch.

Note: Usually there is only one tab that is bent down on the lock nut. If there are others, straighten them as well.



Step 20 Continued

Straightening the lock washer tab.



Step 21

Using a wheel bearing nut socket

Note: To purchase one of these sockets through Low Range Off-Road click [HERE](#).



Step 22

Remove the wheel bearing lock nut.



Step 22 Continued

Wheel bearing lock nut removed.



Step 23

Remove the locking washer.



Step 24

Remove the bearing adjustment nut using the same socket as before.



Step 24 Continued

Bearing adjustment nut removed.



Step 25

Remove the thrust washer.



Step 26

Slide the hub off the spindle and set it aside for now.

Note: The outer bearing, inner bearing and hub oil seal will come off with the hub.



Step 27

Remove the dust shield, spindle and caliper holder by removing the (4) bolts using a 12 mm socket.



Step 27 Continued

Dust shield, spindle and caliper holder removed.



Step 28

Remove the (4) top king pin bolts using a 12 mm socket.

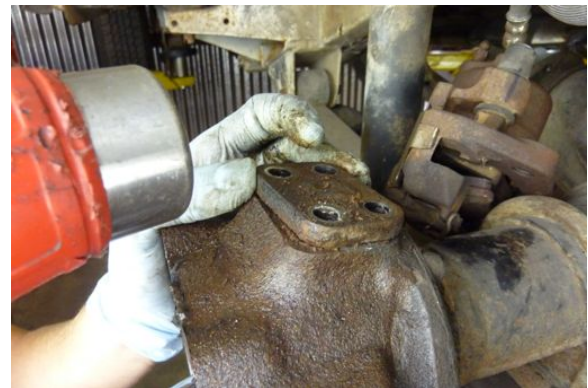

Step 29

Tap the king pin loose with a ball peen hammer. Keep working it back and forth in a rotational direction until there is an opening, larger enough, to pry with a screwdriver. See next step.



Step 29 Continued

Using a large standard screwdriver, pry upward on the king pin.

Caution: There is usually a shim below this king pin. Be careful not to damage it. You will, most likely, have to use this shim during reassembly.



Step 29 Continued

Pry in several locations. Work carefully and slowly. This may take a few minutes. The king pin must move **straight** up to be removed without damaging it.



Step 29 Continued

King pin removed.



Step 30

Before removing the lower king pin, mark it with a file or punch so it can be identified. The bottom king pin must be reinstalled on the bottom and the top king pin on the top.



Step 31

Remove the lower king pin in same way you did the top.



Tech Tip

If there are shims under the king pins, they must be reinstalled in the same locations. Be sure to mark them or set them aside so you will know where they are to be placed during reassembly.



Step 32

Remove the (6) oil seal cover bolts using a 12 mm socket.



Step 33

Pry loose the oil seal cover halves (front and rear) using a standard screwdriver.



Step 33 Contented

Oil seal covers removed.



Step 34

Remove the felt dust pad and set it back on the axle housing.



Step 35

Using a standard screwdriver, remove the (2) retainer ring halves and knuckle ball seal.



Step 35 Continued

Knuckle ball seal and (2) retainer ring halves removed. Lay the seal on the axle housing.



Step 36

Remove the steering knuckle and set it aside.

Caution: The bottom king pin bearing may fall out.



Step 37

Remove the bottom king pin bearing and set it aside.

Note: If you plan to reuse these bearings they must be installed back in the same location they came from.

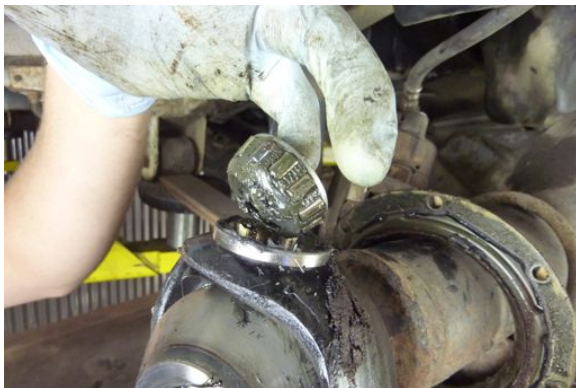

Step 38

Remove the upper king pin bearing and set it aside.



Step 39

Remove the axle shaft and set it aside.



Step 40

Wipe the knuckle ball clean using a cloth.



Step 41

Remove the seal retainer rings from the knuckle ball seal if not done previously.

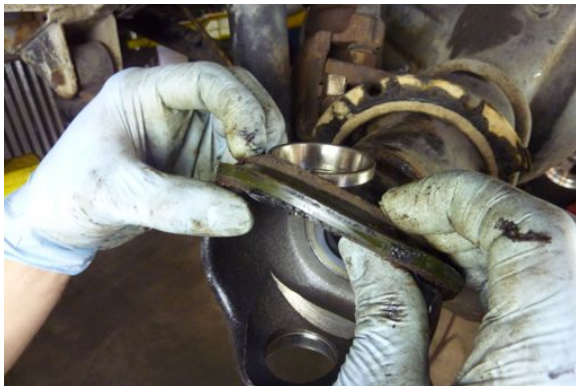

Step 42

Remove the knuckle ball seal from the knuckle ball.



Step 43

Remove the felt dust pad.

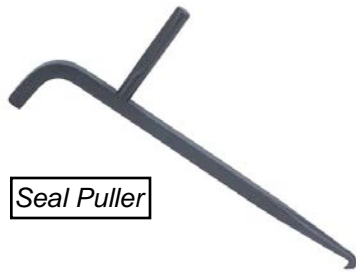

Seal Puller



Step 44

Using a seal puller, remove the inner axle seal.



Tech Tip

This is another style seal puller that works well.



Step 45

Repeat **Steps 2 through 44** on the driver side front wheel.



If you are installing our LROR Chromoly Birfield Axles (or any other 26 spline axles) go to our "Suzuki Samurai HD Front 4340 Chromoly Birfield Axle Set" instructions found in the "Tech and Instructions" tab at www.lowrangeoffroad.com or click [HERE](#).



Installing the King Pin Bearings

If axles are installed, remove them.



Step 46

Drive out the top king pin bearing race using drift punch and hammer.

Note: You may have to hit the race in several locations to knock it loose.



Step 46 Continued

Positioning of the drift punch.



Tech Tip

Bearings and races come as a matched set. Bearing life could be reduced if bearings and races are mismatched.

Note: Mark the top bearing and set it aside.

Step 47

Position the new bearing race as shown and drive it in using a BRASS hammer. (A block of wood and a ball peen hammer works well if you don't have a brass hammer) The bearing must be driven in evenly by alternating hits on each side of the race. Continue until the race is completely seated.

Note: Be sure the race is positioned with the larger inside diameter, facing upward.





Step 48

Remove and replace the lower king pin bearing race by repeating **Steps 46 and 47.**



Step 49

Position the new seal with the garter spring facing away from you.



Step 50

Position the seal in the axle and drive it into place using a socket that is a little smaller than the seal.

Notice: Stop driving the seal when it is flush with the housing.



Step 51

Place the new felt dust pad over the knuckle ball as shown.

Caution: Take care not to tear the felt.



Step 52

Place the new knuckle ball seal over the knuckle ball.



Tech Tip

This side of the seal goes outward when installing the seal on the knuckle ball.



Step 53

Apply a small amount of grease to the axle seal to protect it when installing the axle shaft.



Notice:

The photographs used in the following instructions show our HD 4340 Chromoly Axle shafts. Whether you are installing new chromoly axle shafts or reusing the OEM Suzuki shafts, the procedure is basically the same.

If you are installing 26 spline Chromoly axle shafts (or any aftermarket 26 spline axle shafts) and would like to access our full color instructions click [HERE](#) or go to www.lowrangeoffroad.com and click on the "Tech and Instructions" tab.



Step 54

Install the axle in the axle housing until it stops. It will stop when it hits the differential. To install the inner end of in the axle, you will need to push down on the birfield end of the axle, which will lift up on the differential end of the axle, aligning it with the differential side gear. You may also need to rotate the axle slightly, while pushing it in, to align the splines.

Note: Be patient. This may take a few moments.



Step 54 Continued

This shows the axle properly installed

Installing the Steering Knuckle and King Pins



Step 55

Clean out the steering knuckle using a cloth and set the knuckle aside.



Step 56

Clean both king pins and king pin shims and set them aside.



Step 57

Pack both king pin bearings (upper and lower) with grease. This is done by placing a golf ball size amount of grease in the palm of the hand and holding the bearing with the thumb and forefinger, force small amounts of grease into the bottom of the bearing until it appears at the top.



Step 57 Continued

This shows grease starting to appear at the top of the bearing between the rollers. Once it appears between 3 or 4 rollers, rotate the bearing to another section and continue packing. Continue this procedure until grease is observed between all the rollers indicating that the bearing is full.

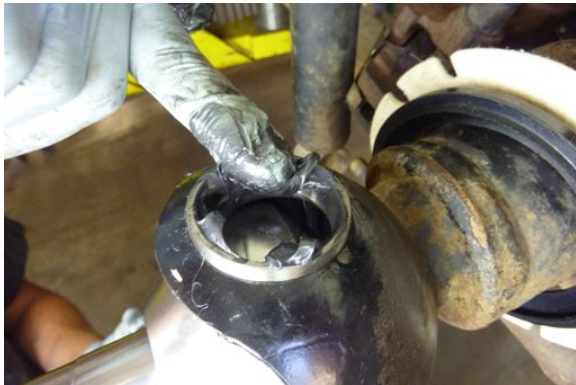

Step 58

Apply a layer of grease to the top and bottom bearing race as shown.



Step 59

Place the top king pin bearing in the top race.



Step 60

Install the bottom king pin bearing in the bottom race.

Note: The grease should hold this bearing in place long enough to install the steering knuckle.



Step 61

Install the steering knuckle.



Step 62

Align the steering knuckle, bearing and the king pin and install the top king pin. If there was a shim under this king pin during disassembly, be sure to install it back where it was.

Note: If there was no shim here during disassembly, don't worry about a shim for now.



Step 63

This may require a couple of light taps with a hammer. Do not pound this part together. If it does not go down fairly easily, check for cleanliness and part misalignment.





Step 64

Install the bottom king pin and king pin shim.



Step 65

Install the bottom king pin bolts and lightly snug them.



Step 66

Install the top king pin bolts and torque them 14 to 21 ft. lbs.



Step 67

While torquing the bottom king pin bolts 14.5 to 21.5 ft. lbs., move the steering knuckle side-to-side. If the steering knuckle gets hard to move while torquing the bolts; stop tightening, remove one of the king pins and add a shim. Shims are supplied in .004" (.1 mm) or .020" (.5 mm) Shims can be purchased on our web site. Click [HERE](#) for more information.



Step 68

Test the king pin bearing preload by using a pull scale. There should be 2 to 4 pounds (or 1.0 – 1.8 kg) required to START knuckle side-to-side movement.

Note: If the scale reading is too high, increase shim thickness of one king pin. If reading is too low, decrease shim thickness of one king pin.



Tech Tip

If you do not have pull scale and you are interested in purchasing one, click [HERE](#). Or go to our website and enter the words "Pull Scale" in the search box.

Installing the Spindle and Hub Assembly



Step 69

Clean the spindle and backing plate using a cloth.



Step 70

Inspect the axle bushing for wear. Replace if needed. Be sure to apply some grease inside this bushing before installation of the axle shaft.

Note: This bushing can be purchased through Low Range Off-Road.



Step 71

Install the dust shield and hub assembly.

Note: There is no gasket here. If you expect to encounter a lot of water we recommend using Permatex® Ultra Gray Gasket Maker here.



Step 72

Install the (4) spindle bolts and torque 14 to 21 ft. lbs.



Step 73

Remove the outside wheel bearing from the hub.

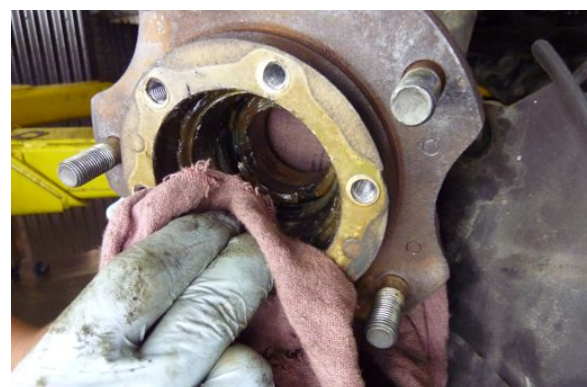

Step 74

Wipe the grease from the hub with a cloth.



Step 75

Remove the locking hub gasket.



Step 76

Remove the outer wheel bearing race using a drift punch and hammer. Hit the race in several locations driving it out evenly.



Step 76 Continued

This picture shows the positioning of the punch.



Step 77

This picture shows the outer bearing race removed.



Step 78

Position two blocks of steel or wood under the wheel studs and drive the inner bearing and hub oil seal out of the hub using a punch and hammer.



Step 79

Using the same set-up drive the inner bearing race from the hub using a punch and hammer.

Caution: The race must be driven out evenly. To accomplish this, strike the race in several different locations around the circumference of the race.



Step 79 Continued

This shows the positioning of the punch to remove the inner bearing race.



Step 80

Wipe out the hub in preparation for the new bearing races.



Step 81

Un-package the new wheel bearing and race.

Note: Even though both the inner and outer wheel bearings and races are the same size and look exactly the same, it is best to keep the races and bearings together as a matched set.



Step 82

Using a brass hammer, drive the inner race into the hub until it is flush with the hub.



Step 83

If you have a bearing race driving tool set, you can use that to finish driving in the race. If you do not have such a set; read on. You can make a bearing race driver out of one of the old races that you removed earlier. All you need to do is grind a small amount of metal from the outside diameter of the race so that it will barely fit inside the hub.



Tech Tip

This shows the old race with the outside removed from grinding. This race needs a little more metal removed before using it as a race driving tool.





Step 84

Place the race driver, thin side down, and finish driving in the new bearing race. Be sure it goes in all the way, until it seats against the shoulder inside the hub.



Step 85

Drive in the outer bearing race in the same way.



Step 86

Wipe out the hub again to be sure it is clean.



Step 87

Pack the inside bearing with grease the same way as you packed the king pin bearings. **(See Step 57)**



Step 88

Wipe a layer of grease on the inner bearing race.



Step 89

Install the inner bearing in the hub.



Step 90

Install the supplied seal.



Tech Tip

One of the old wheel bearing races can be used as a seal driver.

Note: The larger inside diameter side of the race goes toward the seal.



Step 91

Drive the seal evenly into the hub. Continue driving until the seal is flush with the hub.

Caution: This seal can easily be driven in too far. Be careful.



Step 91 Continued

This shows the seal properly installed.



Step 92

Pack the outside wheel bearing with grease, wipe grease on the bearing race and install the wheel bearing in the hub.



Step 93

Clean the spindle with a cloth.



Step 94

Apply a layer of grease on the spindle where the seal will ride.



Step 95

Install the hub on the spindle.

Caution: Be careful that the outer bearing does not fall out on the floor.



Step 96

Install the supplied thrust washer.

Note: Be sure the tab of the washer fits the groove in the spindle.



Step 97

Thread on the supplied bearing adjustment nut.





Step 98

While rotating the hub by hand, torque the adjustment nut to 57 ft. lbs. (8.0 kg-m). Back off the nut until torque becomes 0. Then tighten the nut to 7.5 to 10.5 ft. lbs.

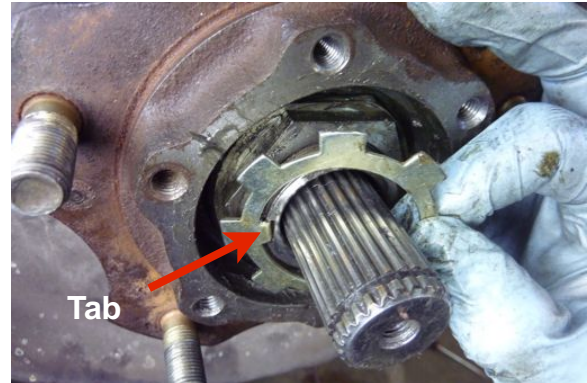

Step 99

Install the supplied locking washer.

Note: Be sure to orient the tab to the groove in the spindle.



Step 100

Install the supplied lock nut and torque it 43.5 to 65 ft. lbs.



Step 101

Locate one of the tabs that aligns with a flat on the lock nut and bend it forward locking the lock nut in place.

Note: This can be done with a large standard screwdriver.



Step 102

Locate another tab that aligns with one of the flats on the adjustment nut and bend it backward, locking the adjustment nut in place.

Note: This can be done with a hammer and chisel or punch.



Step 103

Wipe any grease from the locking hub surface.



Step 104

Position the locking hub gasket and locking hub as shown and install the bolts, lock washers and locking cone washers.

Note: This gasket is not supplied with the kit. If you are interested in purchasing one click [HERE](#). If you do **NOT** have this gasket, Ultra Gray RTV Silicone Gasket Maker works well here. Be sure the mating surfaces are clean and only use a thin layer of RTV.



Step 104 Continued

This shows the bolt, washer, and cone washer assembly properly positioned.





Step 105

While holding the hub with a larger screwdriver snug these bolts up evenly, in a criss-cross pattern. Then torque them 15 to 22 ft. lbs.



Step 106

Temporarily thread a bolt (8X1.25X25mm) in the axle to use as a handle to pull the axle outward, and install the C-clip as shown using snap ring pliers. Remove the bolt.



Step 107

Fit the hub cover gasket on the hub cover as shown.

Note: This gasket is not supplied with the kit. If you are interested in purchasing one click [HERE](#). If you do **NOT** have this gasket, Ultra Gray RTV Silicone Gasket Maker works well here. Be sure the mating surfaces are clean and only use a thin layer of RTV.



Step 108

Apply a layer of grease on the locking hub cover teeth (internal and external) as shown.



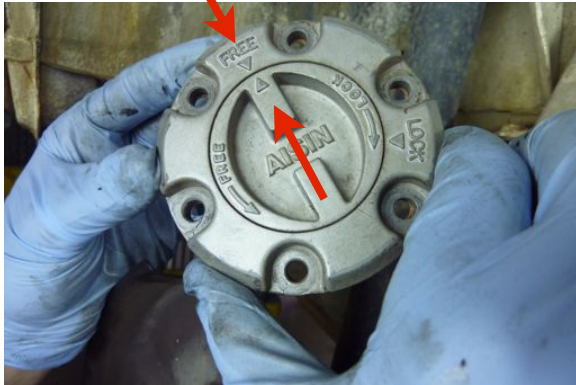

Step 109

Place the locking hub cover in the free position if it is not already there.



Step 110

Install the locking hub cover in the locking hub as shown.

Note: This hub cover only fits in one position. You may need to trial and error a bit to get it to fit properly. Do not force it.



Step 111

Install the bolts and snug them up evenly. The torque spec is 72 to 109 **INCH-Pounds**. If you do not have an inch-pound torque wrench this means about "screwdriver tight". Do not over torque these bolts. They are easily stripped.



Installing the Brakes



Step 112

Install the brake disc.



Step 113

Install the brake caliper and caliper adapter.



Step 114

Install the caliper adapter bolts and torque them 29 to 43 ft. lbs.



Installing the Knuckle Ball Seals



Step 115

Wipe the knuckle ball clean.



Step 116

Apply a thick coat of bearing grease to knuckle ball side of the knuckle ball seal.



Step 117

Position the upper seal retainer ring as shown.



Step 118

Slide the knuckle ball seal into position.



Step 119

Position the felt dust pad into place.



Step 120

Position the front half of the oil seal cover and install the bolt indicated in the picture. Just get the bolt started at this point.



Step 121

Start the second bolt as shown.



Step 122

Slip the bottom half of the seal retainer ring between the steering knuckle and the knuckle ball seal.





Step 123

Start the third bolt as shown.



Step 124

Position the rear half of the oil seal cover and start the 4th bolt.



Step 125

Start the next 5th bolt as shown.



Step 126

Start the rest of the remaining (3) bolts. Before continuing to the next step, double check the seal and all associated parts for proper fit and positioning.



Step 127

Torque the bolts 6 to 8.5 ft. lbs.

Connecting the Tie Rod



Step 128

Reconnect the tie rod and torque the nut to 22 ft. lbs.



Step 129

If the slots in the castle nut align with the holes in the tie rod stud, install a new cotter pin.

Caution: Always use a new cotter pin in these applications.





Step 130

If the slot in the nut does not align with the hole in the stud, as shown here, continue tightening the nut until the hole aligns. Then install the cotter pin and bend one leg as shown in the previous step.

Caution: Never loosen this nut to align the holes; Always tighten.

Step 131

Repeat **Steps 46 through 130** on the driver side wheel.



Step 132

Install both wheel assemblies and torque the lug nuts 36.5 to 57.5 ft. lbs.



Step 133

Lower the vehicle to the floor.



Step 134

Pump the brake pedal 3 or 4 times to insure the brakes are operating correctly before moving this vehicle. After pumping the pedal 3 or 4 times, the pedal should become hard to push at about 1/2 the distance to the floor. If it does not feel right, seek professional help before driving this vehicle.



Congratulation!

You have successfully competed the job. If you have suggestions on how we could make these instructions or our products better, please let us know.





As always, If you experience any difficulty during the installation of this product please contact Low Range Off-Road Technical Support at 801-805-6644 M-F 8am-5pm MST. Thank you for purchasing from Low Range Off-Road.



These instructions are designed as a general installation guide. Installation of many Low Range Off-Road products require specialized skills such as metal fabrication, welding and mechanical trouble shooting. If you have any questions or are unsure about how to proceed, please contact our shop at 801-805-6644 or seek help from a competent fabricator. Using fabrication tools such as welders, torches and grinders can cause serious bodily harm and death. Please operate equipment carefully and observe proper safety procedures.

Rock crawling and off-road driving are inherently dangerous activities. Some modifications will adversely affect the on-road handling characteristics of your vehicle. All products sold by Low Range Off-Road are sold for off road use only. Any other use or application is the responsibility of the purchaser and/or user. Some modifications and installation of certain aftermarket parts may under certain circumstances void your original dealer warranty. Modification of your vehicle may create dangerous conditions, which could cause roll-overs resulting in serious bodily injury or death. Buyers and users of these products hereby expressly assume all risks associated with any such modifications and use.

Revised 05/20/13© Copyright 2013 Low Range Off-Road, LC All Rights Reserved

