



FITTING INSTRUCTIONS

Part Number: **3415010**
Product **ARB WINCH BULL BAR**
Description:
Suited to **TOYOTA TUNDRA YEAR MODELS 07 ON**
vehicle/s:

WARNING

REGARDING VEHICLES EQUIPPED WITH SRS AIRBAG:

When installed in accordance with these instructions, the front protection bar does not affect operation of the SRS airbag.

ALSO, NOTE THE FOLLOWING:

- ◆ This product must be installed exactly as per these instructions using only the hardware supplied.
- ◆ In the event of damage to any bull bar component, contact your nearest authorised ARB stockist. Repairs or modifications to the impact absorption system must not be attempted.
- ◆ Do not use this product for any vehicle make or model, other than those specified by ARB.
- ◆ Do not remove labels from this bull bar.
- ◆ This product or its fixing must not be modified in any way.
- ◆ The installation of this product may require the use of specialized tools and/or techniques
- ◆ It is recommended that this product is only installed by trained personnel
- ◆ These instructions are correct as at the publication date. ARB Corporation Ltd. cannot be held responsible for the impact of any changes subsequently made by the vehicle manufacturer
- ◆ During installation, it is the duty of the installer to check correct operation/clearances of all components
- ◆ Work safely at all times
- ◆ Unless otherwise instructed, tighten fasteners to specified torque

ARB 4x4 ACCESSORIES

Corporate Head Office

42-44 Garden St
Kilsyth, Victoria
AUSTRALIA 3137

Tel: +61 (3) 9761 6622
Fax: +61 (3) 9761 6807

Australian enquiries
North & South American enquiries
Other international enquiries

sales@arb.com.au
sales@arbusa.com
exports@arb.com.au

www.arb.com.au

GENERAL CARE AND MAINTENANCE

By choosing an ARB Bar, you have bought a product that is one of the most sought after 4WD products in the world. Your bar is a properly engineered, reliable, quality accessory that represents excellent value. To keep your bar in original condition it is important to care and maintain it following these recommendations:



- Prior to exposure to the weather your bar should be treated to a Canuba based polish on all exposed surfaces. It is recommended that this is performed on a six monthly basis or following exposure to salt, mud, sand or other contaminants.
- As part of any Pre Trip Preparation, or on an annual basis, it is recommended that a thorough visual inspection of the bar is carried out, making sure that all bolts and other components are torqued to the correct specification. Also check that all wiring sheaths, connectors, and fittings are free of damage. Replace any components as necessary. This service can be performed by your local authorised ARB Stockist.

FITTING REQUIREMENTS

REQUIRED TOOLS FOR FITMENT OF PRODUCT:

Metric socket and spanner sets 8-25mm range		External Circlip pliers	
Screwdrivers, Philips and Flat blade		Dia 22.0 (7/8") holesaw	
Power Drill 13mm (1/2") capacity		Dia 7.0mm (5/16") and 10.0mm (25/64") drill bits	
Hacksaw	Scriber	Centre punch	
Files, round, square and flat	Hammer	300mm Rule	

HAVE AVAILABLE THESE SAFETY ITEMS WHEN FITTING PRODUCT:

Protective eyewear		Hearing protection	
--------------------	---	--------------------	---

NOTE: 'WARNING' notes in the fitting procedure relate to OHS situations, where to avoid a potentially hazardous situation it is suggested that protective safety gear be worn or a safe work procedure be employed. If these notes and warnings are not heeded, injury may result.

FASTENER TORQUE SETTINGS:

SIZE	Torque Nm	Torque lbft
M6	9Nm	7lbft
M8	22Nm	16lbft
M10	44Nm	32lbft
M12	77Nm	57lbft

OPTIONAL LIGHT SETS TO SUIT THIS PRODUCT:

- ◆ ARB P#9249FCK 100mm 55WATT FOG LAMP KIT
- ◆ Up to IPF 900 SERIES FOG OR DRIVING LIGHT SETS
- ◆ IPF 840 FYS FOG LIGHTS CAN BE FITTED TO LOWER PAN AREA
- **FOR IPF OPTIONAL FOG LAMPS, ORDER SUPPLEMENTARY KIT# 9381FCK.**

IF REFITTING OE FOG LAMPS, ADAPTER BRACKETS ARE SUPPLIED STANDARD WITH THIS BULL BAR FITTING KIT TO MOUNT THESE LAMPS.

PARTS LISTING

APPLICATION.	PART NO.	QTY	DESCRIPTION
Mount Brackets To Chassis	3756991R	1	Bracket Mount RHS
	3756991L	1	Bracket Mount LHS
	6151428	2	Flange Nut M12
	6151429	2	Chassis Stud M12 x 265 x 1.75
	6151396	2	Nut Clevis
	5846400	2	Packer M12 x 8mm
Brace Assembly	4681241	1	Brace
	6151357	7	SEMS Bolt M10 x 1.5 x 30mm
	6151321	7	Nut Flanged M10 x 1.5
Bull Bar To Mount Bracket Assy	6151357	2	SEMS Bolt M10 x 1.5 x 30mm
	6151321	2	Nut Flanged M10 x 1.5
	6151255	6	Bolt M12 x 1.75 x 40mm
	6151189	6	Nut M12 x 1.75
	4581049	12	Washer Flat M12
	4581050	6	Washer Spring M12
Stone Tray to Bull Bar	6522671	1	Stone Tray
	6151303	6	Nut Cage 8mm
	6151022	6	Bolt M8 x 25mm
	4581063	12	Washer Flat M8 x25.4 x 3
	4581046	6	Washer Spring M8
Indicators To Bull Bar	6821151R	1	Indicator Assembly RH
	6821151L	1	Indicator Assembly LH
	6151308	4	Screw Self Tapping
	6821116	4	Nut Nylon Plug
	6821152	2	Loom
	180701	6	Scotch Locks
	180302	4	Cable Tie
	6821192	2	Bulb 12V 10W BA15S
Winch To Bull Bar	3756775	1	Bracket Control Box Univ.
	3199790	1	Plate Trim for 16500LB Control Box
	6151364	2	Screw Cap M10 x 30
	4581291	2	Washer Flat M10 BZ
	6151321	2	Nut M10 Flanged
	180302	8	Cable Tie
Winch Hole Cover Fitment (If Not Fitting Winch)	6151128	2	Nut Flange M6
	6151256	2	Screw M6 St/Stl Button Head
	6522048	1	Extrusion Winch Cover
	6191013	1	Panel Winch Cover
	6151046	2	Washer M6
Number Plate To Bull Bar	6151017	4	Bolt M6 x 16
	6151046	4	Washer M6
	6151128	4	Nut M6 Flanged
	3751384	1	Bracket Number Plate
Fog Lamps	3757029	2	Adapter Bracket
	6151300	6	Nut Caged M6
	6151017	6	Bolt M6 X 16
	6151046	6	Washer M6
	4581036	6	Washer Spring M6
	4581306	2	Washer
	3162457	1	Light Aperture Molding RH
3162456	1	Light Aperture Molding LH	
Miscellaneous	6151128	2	Nut Flanged M6
	6151213	2	Bolt M6 X 20 BZ
	4581082	4	Washer Flat M6 X 20 BZ

REMOVAL OF BUMPER



1. If fitted, remove factory bash plate



2. Remove tow hooks and bolts, set aside to be refitted.



3. Remove lower bumper retaining screws.



4. Remove all lower fender liner retaining screws to bumper.

REMOVAL OF BUMPER

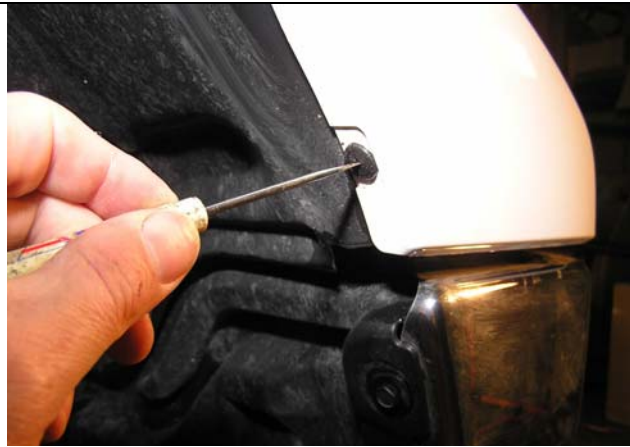

5. Remove upper fender liner retaining scrivets.



6. Prise out lower fender liner plastic push in plugs. Remove lower fender liner completely, they will not be reused.



7. If OE fog lights and/or parking sensors fitted in bumper, undo electrical connections.



8. Remove bumper wing retaining screws in upper wheel arch area.

REMOVAL OF BUMPER

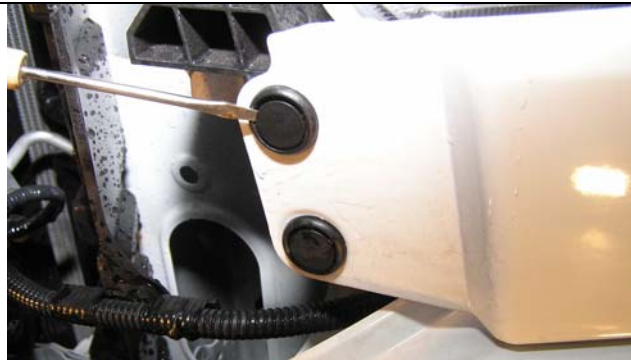

9. Remove push in plugs from trim piece under headlamp.



10. Carefully prise the trim pieces free by pulling them forward and twisting to release plugs out of retaining sockets.



11. Remove screws retaining bumper located under headlamp area.



12. Remove plugs securing upper bumper tabs.

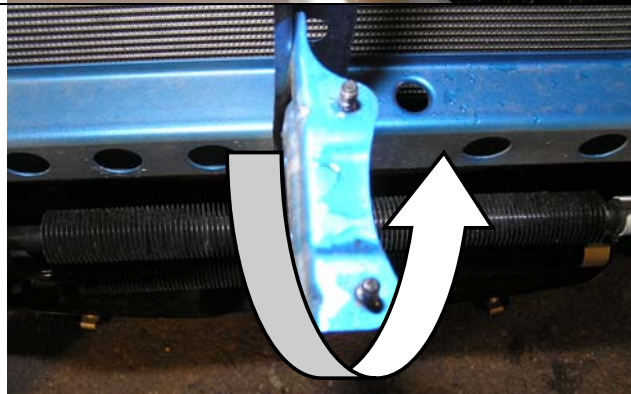

13. If winch is to be fitted to bull bar, bend the forward facing section of vertical brace around and rearwards to prevent interference from winch operation.

REMOVAL OF BUMPER

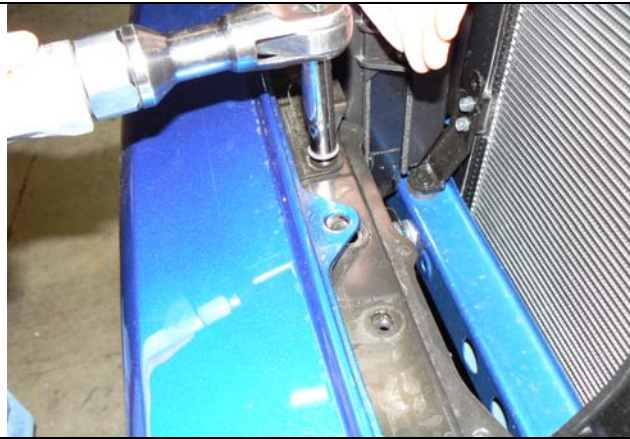

14. Remove screws located along top of cross member retaining upper bumper metal frame.



Removal of bumper.

15. Pull outward and slightly forward on bumper cover in upper wheel arch area to unclip tab on bumper cover from retaining bracket on fender. The bumper and cover should now be released. Carefully remove bumper and set aside.

Hint: *This operation is best performed with two people, one on each end of the bumper.*



16. Remove plastic plugs in cross member.



17. Remove cross member and set aside.

REMOVAL OF BUMPER



18. Undo crash bar mounts from chassis flange.



19. Remove crash bar and lower bumper assembly and set aside, retain flange nuts for reuse.



20. If parking sensors fitted and are to be reused, remove from bumper. Also retain loom tails and set aside.

Note: Remove parking sensor centre from sleeve first. Then remove sleeve from bumper.



21. Remove OE fog lamps if fitted and are to be reused. The plastic surrounds are not to be reused.



22. Remove bumper cover retaining brackets from the fenders.

REMOVAL OF BUMPER

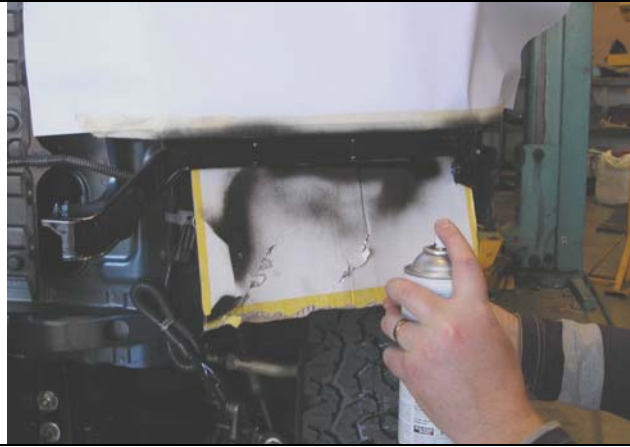

23. Mask up and spray paint the exposed metal trim area black satin, from the wheel arch right around to the inboard headlamp area as shown, both sides of the vehicle.

NOTE: *This is in the area where the bumper cover retaining brackets were removed at step 22. When the bull bar is fitted there will be 25mm of this sheetmetal visible, the black masks the visible gap.*

FIT MOUNTING BRACKETS



24. Insert clevis nut into rectangular hole in the inboard face of chassis, ensuring the threaded end is inserted first.

The nut when fitted correctly should fit square and locate into the chassis rail.



25. Install the chassis stud by fitting 2 nuts to the end of the stud and tightening until thread bottoms out.

26. Remove nuts and repeat for the LHS.



27. Loosely fit the mounting brackets to the chassis securing with the 8mm packers and flange nuts.

28. Secure using existing OE M10 flange nuts, **but do not do up tight.**

FITTING PROCEDURE BULL BAR PREPARATION



29. Centralise the brackets to vehicle and then check the outside measurement across mount brackets, it needs to be 930mm or less. Nip up the M10 flange nuts and tow hooks to better secure mount brackets to chassis.

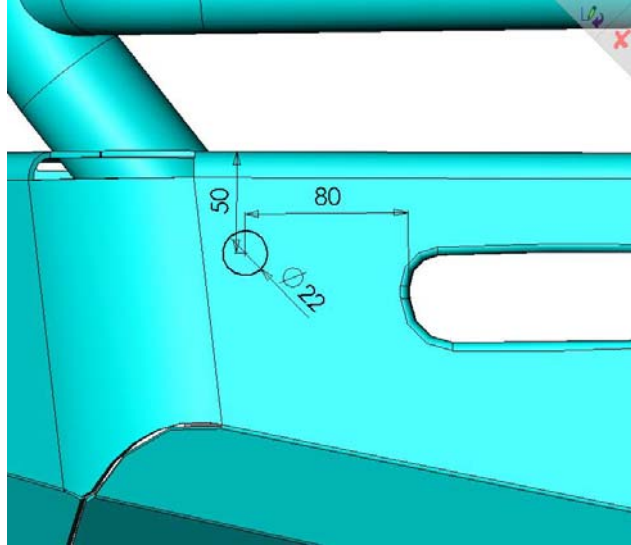

30. If sensors are to be refitted, mark out the hole position as shown on both wings. This position is optimal for sensor operation.

31. Carefully drill the hole with Dia 22.0mm (7/8") hole saw.

CAUTION: Do not make the hole smaller than shown.

32. Deburr any sharp edges.

33. Test fit the sensor sleeve checking that it fits and is not too tight, the inner bore of the sleeve must not be reduced in diameter.



Warning: Drilling operations can result in flying metal debris, safety glasses should be



34. Once sensor hole is cut and sensor has been trial fitted, paint the raw metal edges to prevent corrosion.

35. Fit sensor sleeve into bar first as shown, noting that the tab at rear is up for RHS of bull bar and down for LHS (the same orientation as original OE). Then fit sensor into sleeve.

36. Fit loom extensions and push anchor plug into slot in wing brace next to tube.

Note: Connections are always inboard.

Hint: Take care not to damage sensor electrical connections when removing and refitting.

FITTING PROCEDURE BULL BAR PREPARATION



37. Remove indicators from cartons. Remove fitted screw and speednut assembly. These will not be reused. New screws and grommets are supplied in the fitting kit.

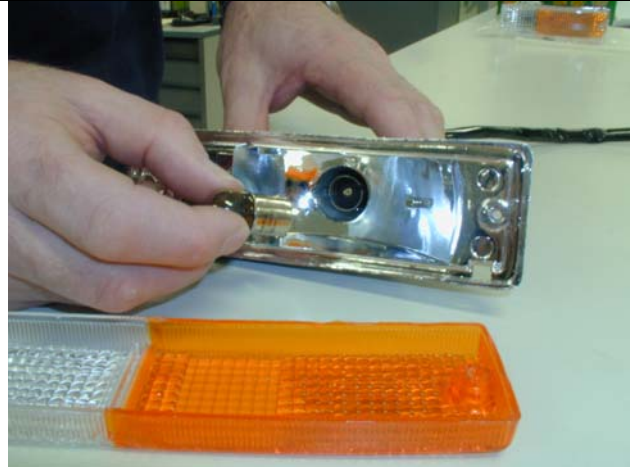

36. With lenses removed, replace 21W light bulbs for indicator (amber reflector side) in supplied indicator/run lamp assemblies with 10W bulbs from fitting kit.



37. Insert nylon nuts into square holes in light brackets inside wing area.



38. Fit lights using screws supplied in fitting kit, taking note of RH and LH light bodies, they are different and must be placed on the correct side of bull bar. Vent holes must be down,

FITTING PROCEDURE BULL BAR PREPARATION

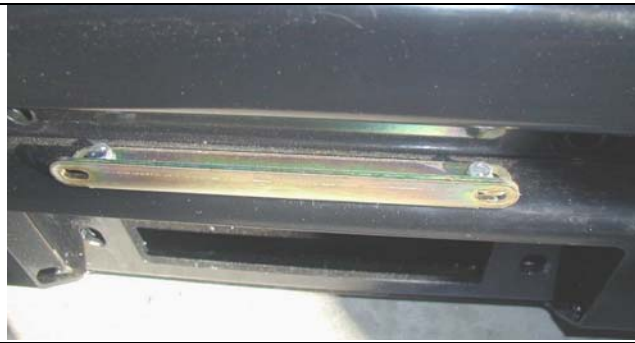

39. Secure the number plate bracket using M6 bolts, flat washers and flange nuts. Attach the longer side to the bullbar and the shorter side to the number plate.



40. Fit M8 cage nuts for stone tray in four positions to inside face of lower pan.

FITTING PROCEDURE WINCH



ORIGINAL POSITION

NEW POSITION

If fitting winch.

41. The clutch handle must be repositioned so it is in a convenient location when mounted to bar.

Place the winch on its end and remove all gearbox bolts.

Gently raise the motor just enough to rotate it. Viewing from the gearbox end, rotate the gearbox 72° clockwise.

Do not completely remove the motor and avoid damaging the gasket. Refit and tighten all bolts.

Note: Take care not to lift the assembly more than a couple of millimeters while rotating to the desired position to avoid un-meshing the gears.



42. Remove cable retaining band and position cable loop so it will go through roller fairlead when it is placed in bull bar.

FITTING PROCEDURE WINCH



Fit control box to pan:

- For 9500-12000lb winches, use universal control box bracket supplied, attaching to rear of control box mount studs.
 - Slide bracket flange under pan and align with mount slots.
43. Fasten in position with 2 x M10 cap screws, black washers and flange nuts



- For 15000lb winches, use Warn supplied control box bracket, attaching to rear of control box mount studs.
 - Slide bracket flange under pan and align with mount slots.
44. Fasten in position with 2 x M10 cap screws, black washers and flange nuts.



- For 16500lb winches, apply Sikaflex (or similar product) to rear of control box trim plate from fitting kit (note orientation critical to suit final position with control box profile in pan opening).
 - Position trim plate on top of pan centrally about control box opening and line up with mount slots.
45. Fasten in position with 2 x M10 cap screws and flange nuts from fitting kit.

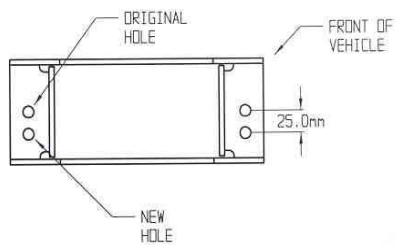

46. In some cases, the roller fair lead bracket must have a second set of holes drilled to line up with holes in winch bracket. If required, mark out as shown and using a 13.0 mm drill bit, drill two holes as shown in diagram.



Warning: Drilling operations can result in flying metal debris, safety glasses should be

FITTING PROCEDURE WINCH



47. Viewed from front of vehicle the winch clutch (handle) must be positioned on the LH side (same side as smaller square access hole in pan). Cable must spool from the bottom of winch. Draw off enough cable so cable crimp can be pulled through roller fairlead.

48. Bolt winch in position with the roller fair lead in place.

Hint: To increase access to mount bolts in front of roller fairlead, remove circlips from bottom of each vertical roller shaft, push shaft up so roller can be dislodged sideways. Do up bolts in fairlead and winch, then refit circlip.

49. Connect the winch control box cables to the winch motor. Refer to the Warn handbook for additional information. Connect the long winch + & - cables to the vehicle after the bar is installed. **Refer to the Warn winch manual for vehicle wiring instructions.**



Fitting number plate – with winch

50. Bolt number plate to the bracket with the M6 X 16mm bolts and M6 flange nuts through the lower holes of the number plate.

If not fitting winch.

51. Bolt the number plate through the top holes using M6 X 16mm bolts and M6 flange nuts.



If not fitting winch cont.

52. Wrap rubber extrusion around winch cover, trim to length.

53. Place M6 flat washers over holes in the top face of the bull bar where the winch cover is fixed to the bull bar.

NOTE: The M6 washers support the cover and prevent dipping around the screw heads.

54. Place the winch cover in position as shown with screws aligning through the mount holes and leaving the washers in place.

55. Bolt together using the M6 button head stainless steel screws and M6 nuts.

FITTING PROCEDURE BAR ON VEHICLE



56. Using two people, three if winch fitted, position the bar assembly on the vehicle mounts.

Caution: *This product is heavy, especially if a winch is fitted. Do not attempt to lift it and fit it by yourself. Have some assistants help you or use a mechanical aid such as a hydraulic lift table.*



57. Bolt the bar to the mounts using M12 bolts. Large flat washers and spring washers. Centralise the bar to the front of the vehicle.
58. Fit the cross brace to underside of lower pan and on top of gussets in mount brackets. Use M10 x 30mm SEMS bolt and washer sets, flange nuts but do not do up tight. If holes in pan do not line up, run a Dia 10.0 drill through any holes to enable bolt entry.



Warning: Drilling operations can result in flying metal debris, safety glasses should be



59. Tighten up the mount brackets fasteners. Start with the tow hook bolts, then M10 flange nuts to chassis studs.
60. Then tighten up the long M12 chassis studs, ensuring that the clevis nut is positioned correctly over the hole in the chassis.

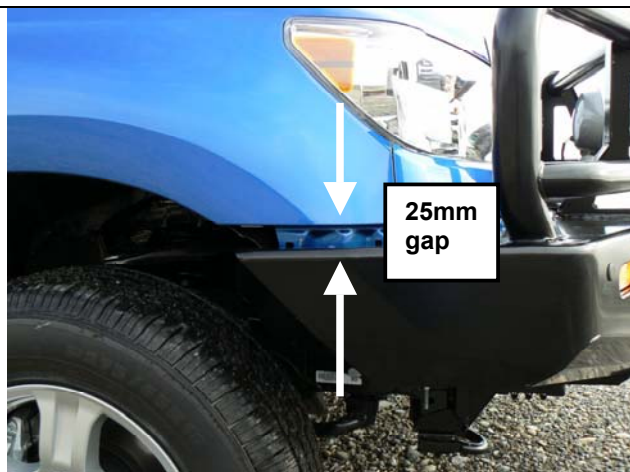

61. Adjust the bar height leaving approximately 25mm gap between top of wing to fender. Align the bar so the front face is vertical and the gap is even on both sides of the vehicle.

FITTING PROCEDURE BAR ON VEHICLE



62. Tighten M12x 40mm mounting bolts.
63. Tighten up the M10 brace bolts in 7 places.



64. Using the M10 pilot hole in mount brackets, drill pinning hole through uprights of bull bar. Fit M10 SEMS bolt and flange nut, do up tight.



Warning: Drilling operations can result in flying metal debris, safety glasses should be

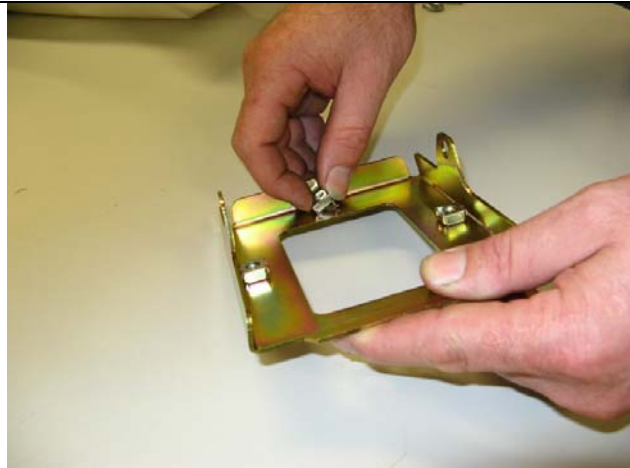

If fitting optional accessory fog lamps kit **9381FCK** follow fitting instructions supplied with kit. If fitting OE fog lights follow steps 65 – 70.

65. Fit M6 cage nuts to adaptor bracket as shown.

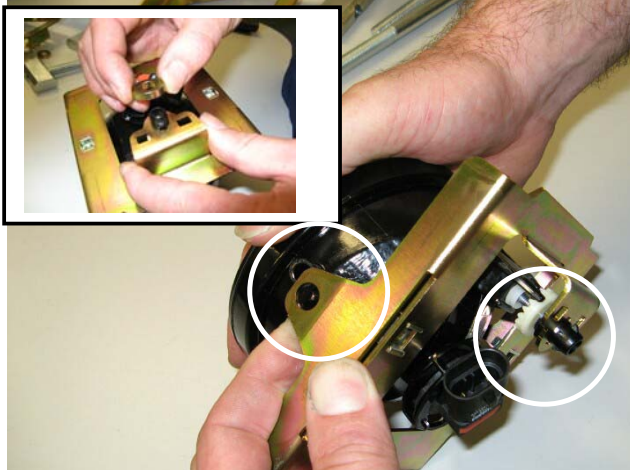

66. Fit light to adaptor bracket by locating mount lugs from light body into holes in adaptor bracket flanges.
67. Push adjuster knuckle nut through the hole in bracket and fit washer OD 20mm x ID 11mm x 4mm thick to secure it. Adjust light so it will sit vertical when fitted to bar.

FITTING PROCEDURE BAR ON VEHICLE

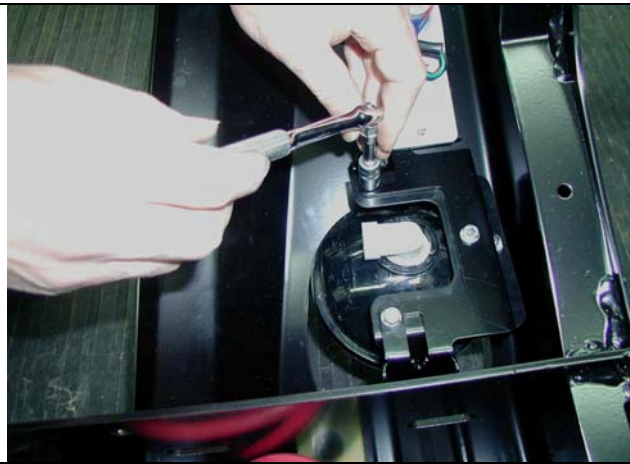

68. Fit adapter bracket and fog lamp assembly into brackets in bull bar wings, as shown.
69. Bolt in place with M6 x 16 bolt and washer sets into cage nuts.



Fitting plastic fog lamp aperture moldings.

70. If fog lamps are to be fitted, cut centre panel out of light aperture moldings using a hack saw blade.
71. If fog lamps are not fitted leave centre panel in place.



72. Note that the aperture moldings are handed (RH or LH), select correct hand for each wing aperture. Apply Sikaflex to recess in aperture molding flange or face of wing then fit molding aperture in wing.



73. Use adhesive tape to secure plastic mold while Sikaflex cures.

FITTING PROCEDURE BAR ON VEHICLE

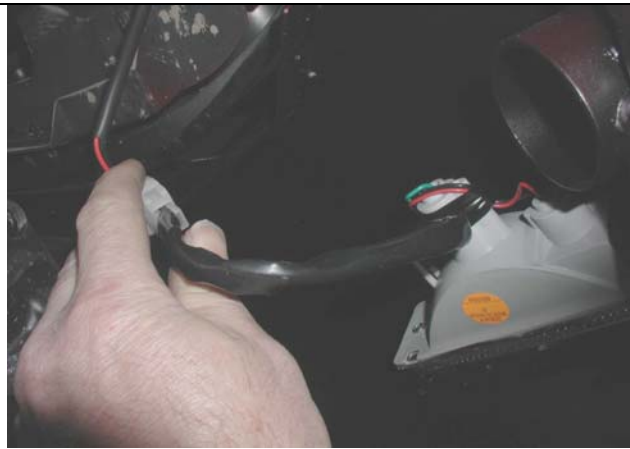

74. Wire up indicators and running lamps. Wire loom extensions are supplied in fitting kit.

Note:

Wiring of indicator looms;

Black = ground

Green = indicator (amber)

Red = run lamp (clear)



75. Trim fender liner if required. Tuck behind wing return.

76. Drill Dia 7.0 hole through fender liner flange behind wing return using existing hole in wing as guide.

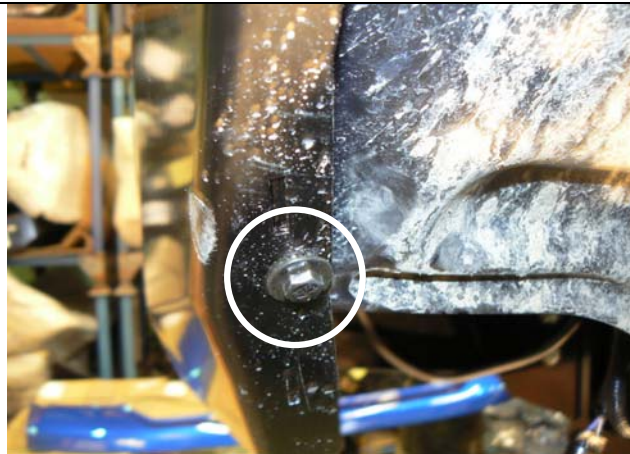

77. Then secure fender liner using M6 x 20 black bolts and 2 x black washers with flange nut.

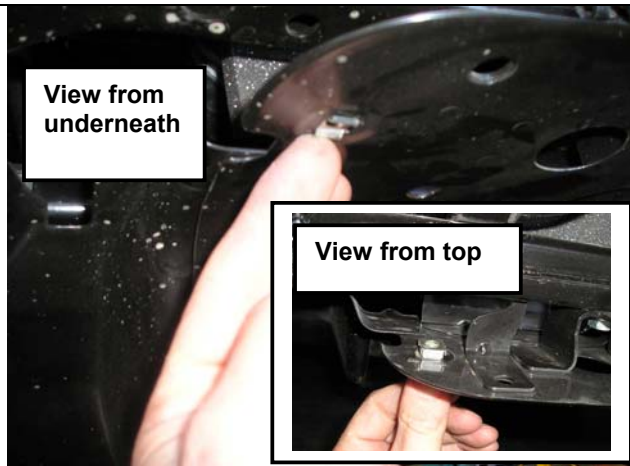

78. Using square file, increase slot length in 2 x existing holes in sump guard (those pitched 570mm apart) to a size of 12.3mm A/F.

79. Fit two M8 cage nuts to slots in sump guard (NOTE: nut body above panel as shown).

FITTING PROCEDURE BAR ON VEHICLE



80. Fit stone tray using 4 x M8 bolts and washer sets at front and 2 x M8 bolts, washers and into fitted M8 cage nuts at two locations into existing sump guard front section as shown.



81. If winch fitted, fit off winch hook.

NOTE:

- ◆ **Connect wiring to fitted sensors, lights and winch.**
- ◆ **Check operation of all lights.**
- ◆ **Check operation of parking sensors. If sensors do not function correctly refer to steps 28 - 34 in notes.**
- ◆ **Adjust fog lamp beam aim.**
- ◆ **Check winch operation**

FITTED PRODUCT

