

INSTALL INSTRUCTIONS



FJ80/FJ100 LAND CRUISER PART TIME 4WD KIT

304187-1-KIT (1990-1997 TOYOTA LAND CRUISER FJ80, 1995-1997 LEXUS LX 450)
(1998-2007 TOYOTA LAND CRUISER FJ100, 1998-2007 LEXUS LX 470)

KIT CONTENTS



304188-1-INS



5356 PINE AVE • FRESNO, CA • 93727
USA TOLL FREE: 877.4X4.TOYS • WORLDWIDE: 559.252.4950
WWW.TRAIL-GEAR.COM



RECOMMENDED TOOLS

Flat Head Screwdriver	Transmission Jack
Rubber Mallet	Wheel Bearing Grease
Safety Glasses	Removable Threadlocking Compound (Loctite 242 or equivalent)
Metric Ratchet & Socket Set	Razor Blade
Metric Wrench Set	Degreasing Compound (e.g. Brake Cleaner)
Arbor Press	Plastic Hammer
Bearing Separator	Torque Wrench
Metric Allen Wrench Set	Snap Ring Pliers
Brass Bar	Ball Peen Hammer
API GL5 SAE 75W-90 Gear Oil (Approximately 1.5 quarts)	

ADDITIONAL PARTS REQUIRED

FJ80 or FJ100 Manual Locking Hubs
6mm or 8mm Axle End Float Spacers (FJ80 Land Cruisers Only)
Center Differential Lock Switch (1991-1995 – OEM P/N 84725-60010, 1995-1997 OEM P/N 84724-60040 or 84725-60040)

CAUTION

1. Read all instructions completely and carefully before you begin. If anything is not clear, please call our tech support line at 1.877.4X4.TOYS or 559.252.4950 or email tech@trail-gear.com before proceeding.
2. Check to make sure the kit is complete and that no parts are missing (refer to the Kit Contents Section on the first page of these instructions). If anything is missing, please contact Trail-Gear at 1.877.4X4.TOYS or 559.252.4950.
3. Park vehicle on a clean, dry, flat, level surface and block the tires so the vehicle cannot roll in either direction.
4. This product is for off-road use only. It is recommended that the installation steps below be performed by a competent mechanic. Buyers and users of this product hereby expressly assume all risks associated with the installation and use of this product.
5. This installation is typical for most FJ80/FJ100 Toyota Land Cruisers. Some vehicles may vary. If necessary, refer to the proper Factory Service Manual for the year and model of your vehicle.



INSTALL INSTRUCTIONS (CONT'D.)



INSTALLATION STEPS

STEP 1

Align the holes in the plastic spacer with the threaded holes in the spool. Carefully press the plastic spacer onto the spool.

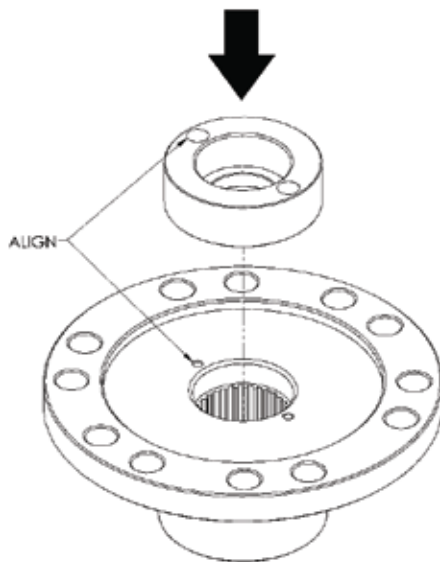

STEP 2

Apply blue (removable) threadlocking compound to the threads of the M4 screws supplied with the kit. Install the screws onto the spool assembly.

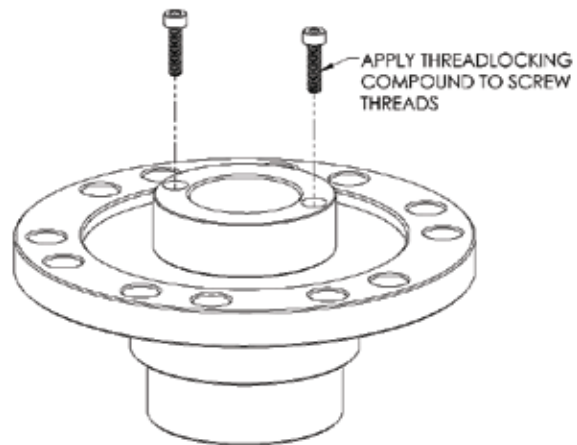

STEP 3

Shift your vehicle into 4WD low and place the transmission in Neutral.

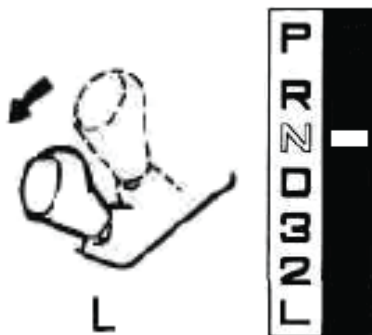

STEP 4

Remove the transfer case drain plug and drain the oil. Discard the used oil in accordance with all local laws. Many auto parts stores will accept used oil for little or no cost. Save the drain plug for reinstallation.



STEP 5

Place match marks on the rear differential driveline flanges. Loosen and remove the (4) driveline nuts and bolts. Save the (4) nuts and bolts for reinstallation.



STEP 6

Place match marks on the rear transfer case driveline flanges. Loosen and remove the (4) driveline nuts and bolts. Remove the rear driveline. Save the driveline and the (4) nuts and bolts for reinstallation.



INSTALL INSTRUCTIONS (CONT'D.)



STEP 7

Place a transmission jack underneath the transmission. Unbolt the crossmember and carefully lower the drivetrain 2-3 inches. Save the crossmember and the mounting hardware for reinstallation.

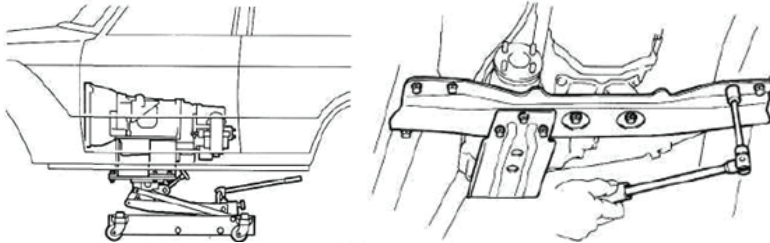

STEP 8

Disconnect the breather hose from the rear transfer case housing.

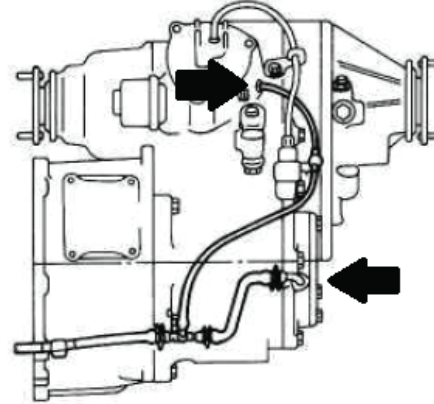

STEP 9

Disconnect the 4WD position switch electrical plug, the neutral position switch electrical plug, the speedometer cable, and the ground wire from the rear extension housing.

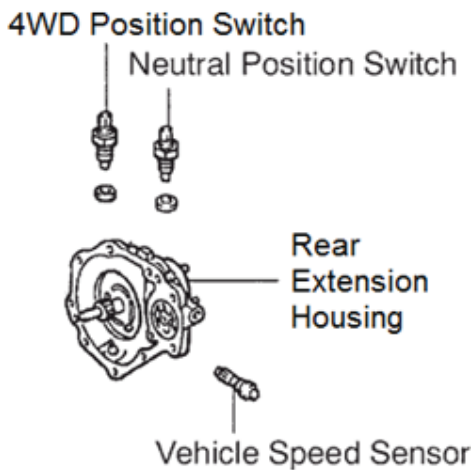

STEP 10

Loosen and remove the (9) bolts from the rear extension housing. Save the (9) bolts for reinstallation. If needed, tap the rear extension housing with a rubber mallet to break the RTV on the sealing flanges. Remove the rear extension housing and save for reinstallation. Note: Not all of the bolts are the same length, so mark the position of each bolt.

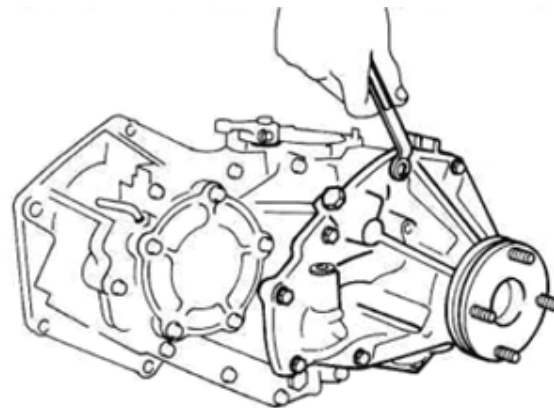

STEP 11

If your FJ80 Land Cruiser is from the 1991-1992 model year, skip to the next step. If your vehicle is from the 1993-1997 model year, you will need to remove the viscous coupler from the rear extension housing. Using snap ring pliers, remove the snap ring from the rear output shaft. Remove the viscous coupler from the rear output shaft. Discard the snap ring and the viscous coupler.

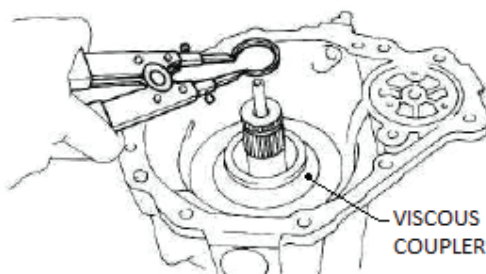

INSTALL INSTRUCTIONS (CONT'D.)



STEP 12

Remove the (8) bolts on the rear transfer case housing. Save the (8) bolts for reinstallation. If needed, tap the rear transfer case housing with a brass bar to break the RTV on the sealing flanges. Remove the rear transfer case housing and save for reinstallation. Note: The input shaft assembly will still be attached to the rear transfer case housing.

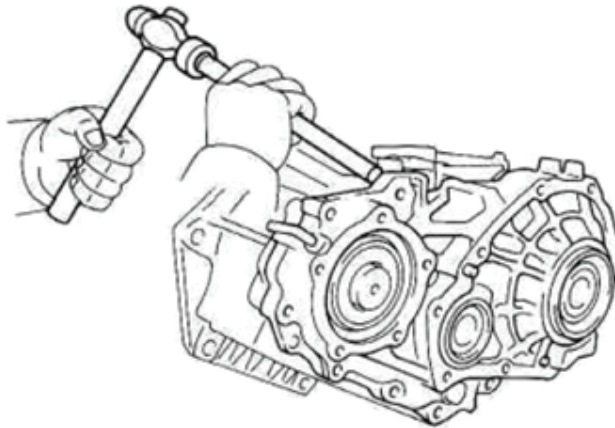
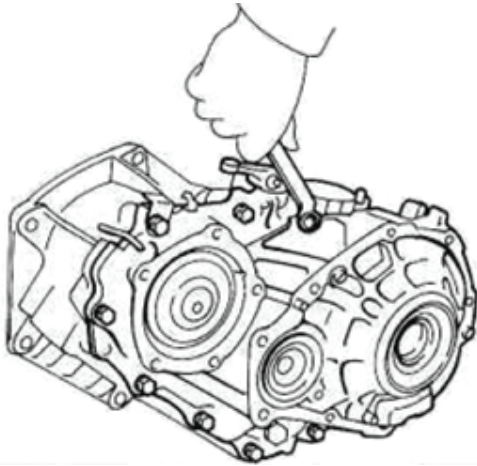

STEP 13

Loosen and remove the (12) bolts from the center differential assembly. Save the (12) bolts for reinstallation. Note: DO NOT remove the entire center differential assembly from the transfer case.

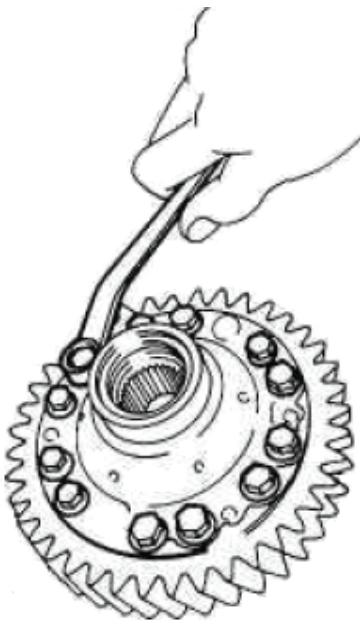

STEP 14

Using a brass punch, gently tap behind the roller bearing to remove the rear differential case from the front differential case. Save the rear differential case for later use.



INSTALL INSTRUCTIONS (CONT'D.)



STEP 15

Remove the rear side gear and thrust washer. Discard the rear side gear and thrust washer.

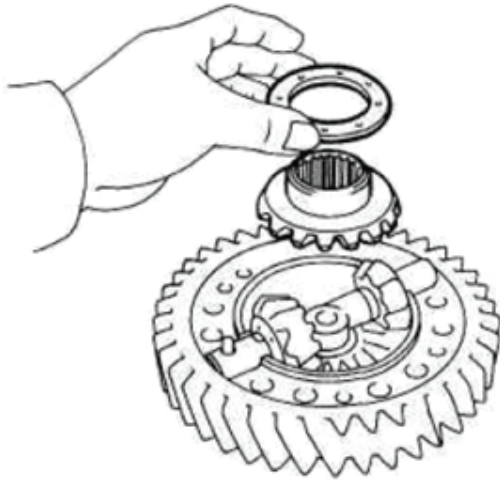

STEP 16

Remove the pinion shaft pin. Remove the pinion shaft, pinion gears, and thrust washers. Discard the pinion shaft pin, pinion shaft, pinion gears, and thrust washers.

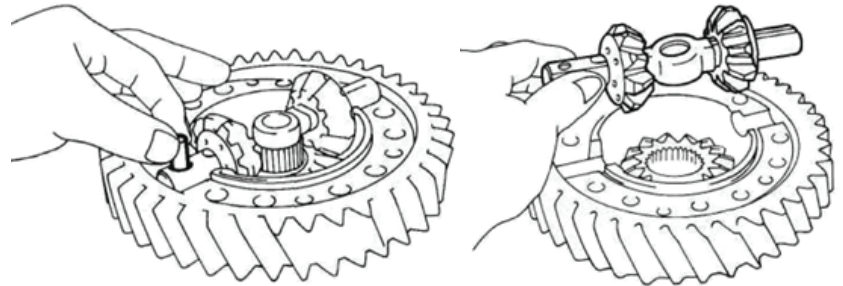

STEP 17

After you have removed the rear side gear and pinion gears, the center differential assembly should look like the picture below.



STEP 18

Using a bearing separator, press off the roller bearing from the rear differential case. Save the bearing for reinstallation. Discard the rear differential case.

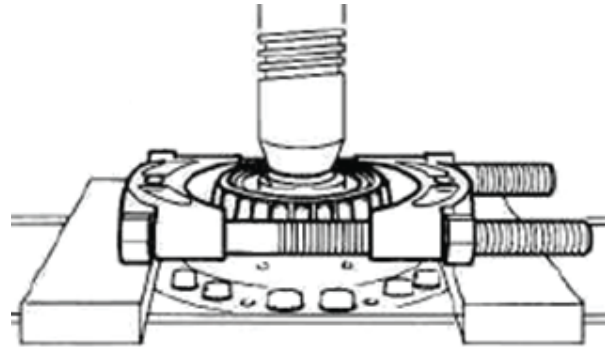

STEP 19

Using an arbor press, install the roller bearing onto the spool assembly.



NOTE: Make sure to apply pressure to the inner race only. **DO NOT** apply pressure to any other part of the bearing, as it will damage the bearing. A similar size piece of pipe or socket will work as long as it contacts the inner bearing race only.

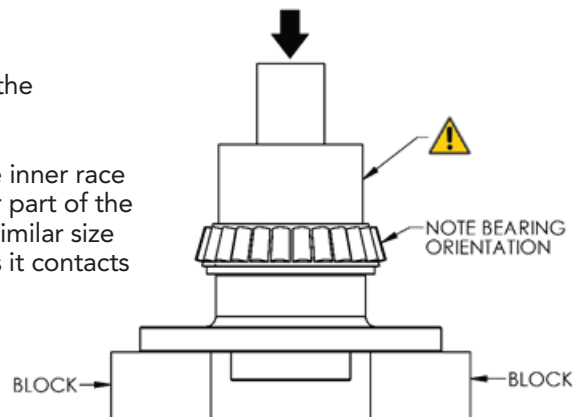

INSTALL INSTRUCTIONS (CONT'D.)



STEP 20

Install the spool assembly onto the differential front case. Apply blue (removable) threadlocking compound to the (12) bolts removed in Step 13. Install and tighten the bolts. Using a torque wrench, tighten the bolts to 65 ft-lbs (88 N-m).

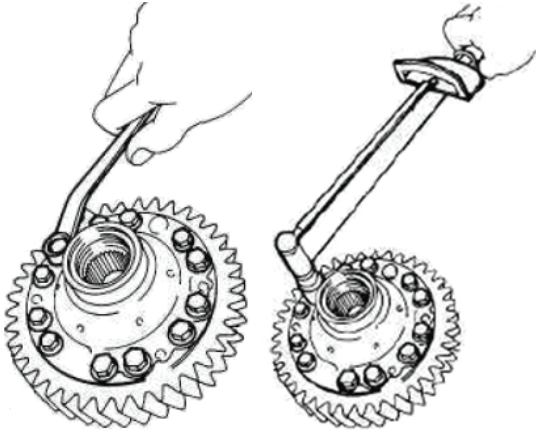

STEP 21

Loosen all (12) bolts. Using a torque wrench, retighten the (12) bolts to 72 ft-lbs (98 N-m).

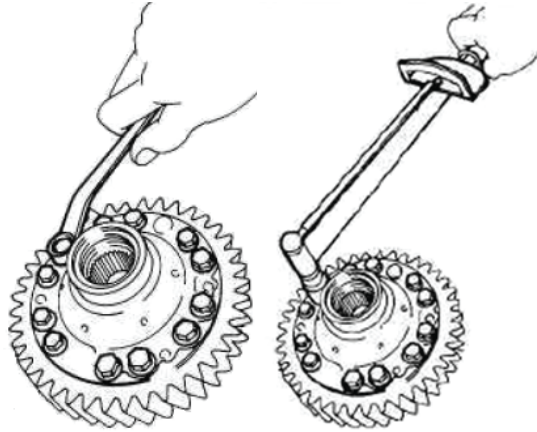

STEP 22

Apply a generous coat of wheel bearing grease to the roller bearing rollers.

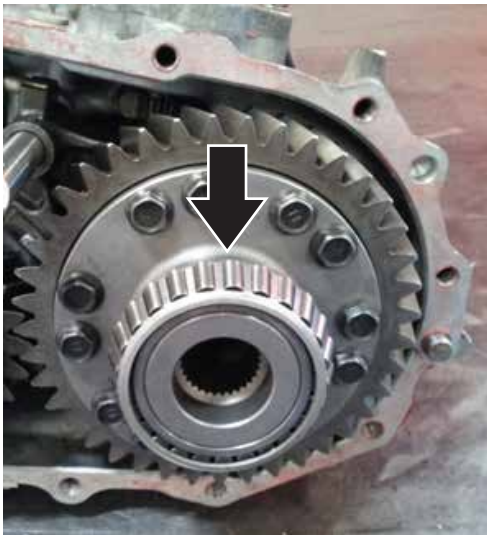

STEP 23

Using a razor blade, remove the RTV and/or gasket remnants from all sealing surfaces on the transfer case housing components. Degrease the flanges with a suitable degreasing agent (e.g. brake cleaner). Make sure all flanges are clean and free of oil.

STEP 24

Apply an even bead of RTV silicone around the perimeter of the front case flange.

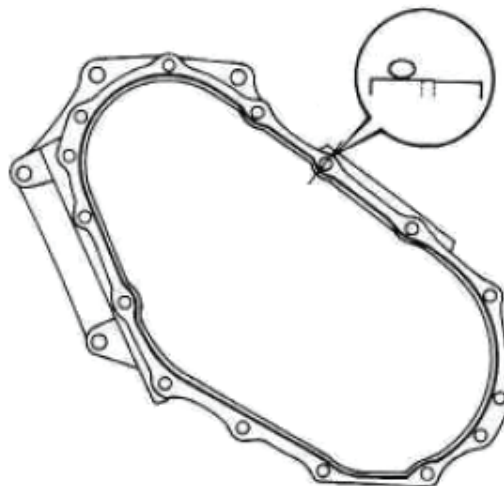

INSTALL INSTRUCTIONS (CONT'D.)



STEP 25

Install the rear case onto the front case. Using a plastic hammer, tap on the rear case to fully seat it.

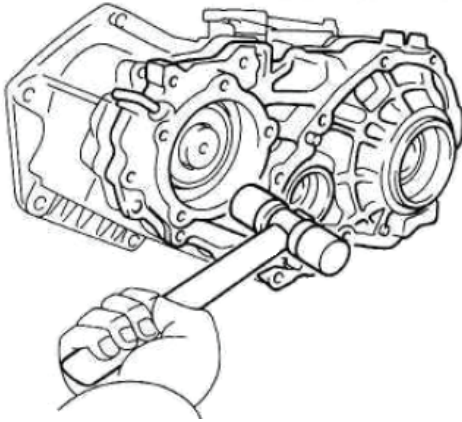

STEP 26

Reinstall the (8) bolts removed in Step 12. Apply blue (removable) threadlocking compound to the (2) bolts marked "A" in the diagram below. Torque the bolts to 27 ft-lbs (37 N-m).

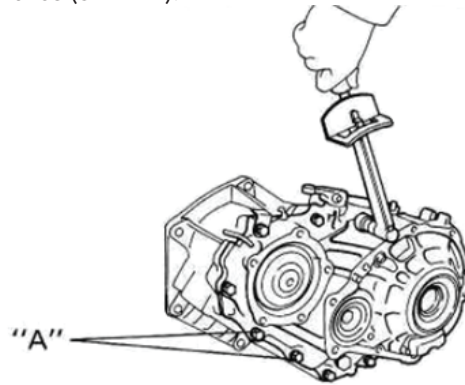

STEP 27

Apply an even bead of RTV silicone around the perimeter of the rear extension housing flange on the rear case.

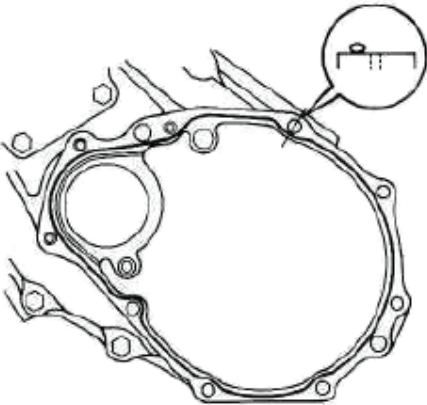

STEP 28

Reinstall the (9) bolts removed in Step 10. Torque each bolt to 27 ft-lbs (37 N-m).

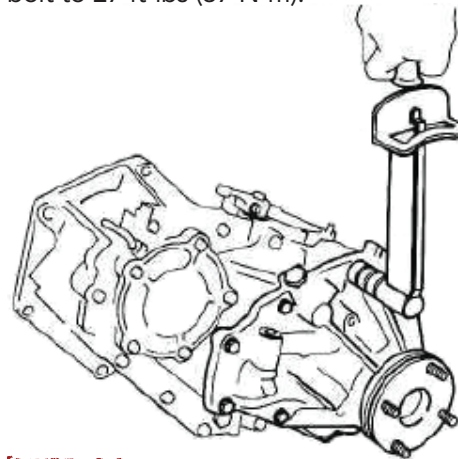

STEP 29

Apply an even bead of RTV silicone around the perimeter of the rear extension housing flange on the front case.

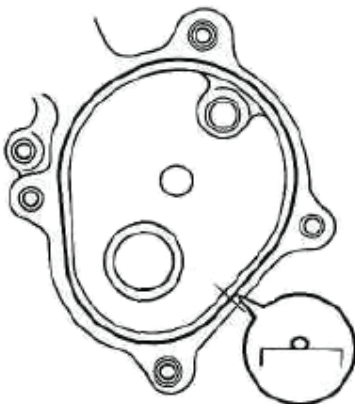

STEP 30

Connect the 4WD position switch electrical plug, the neutral position switch electrical plug, the speedometer cable, and the ground wire from the rear extension housing.

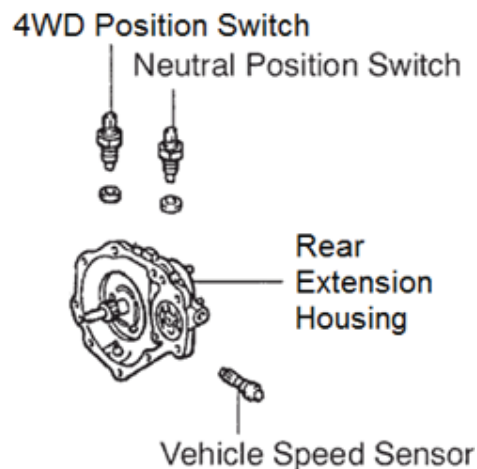

INSTALL INSTRUCTIONS (CONT'D.)



STEP 31

Reinstall the breather hoses.

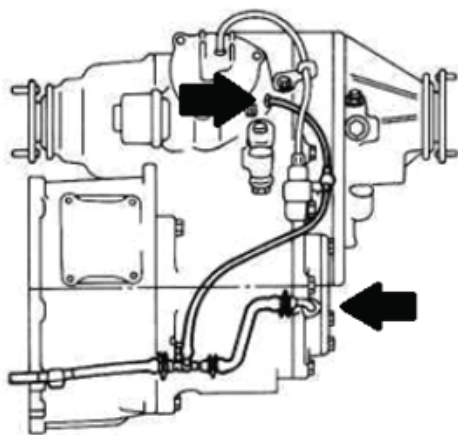

STEP 32

Reinstall the driveline onto the rear differential. Make sure the match marks you put in Step 5 align. Reinstall the (4) driveline bolts and nuts and torque to 65 ft-lbs (88 N-m).

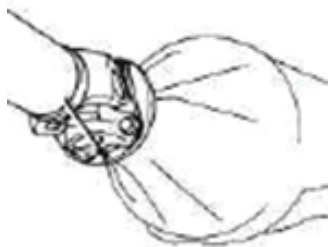

STEP 33

Reinstall the driveline onto the rear of the transfer case. Make sure the match marks you put in Step 6 align. Reinstall the (4) driveline bolts and nuts and torque to 65 ft-lbs (88 N-m).



STEP 34

Raise the transmission and reinstall the crossmember. Torque the bolts to 45 ft-lbs (61 N-m) and the nuts to 54 ft-lbs (74 N-m). After all the crossmember bolts are reinstalled and torqued, remove the transmission jack.

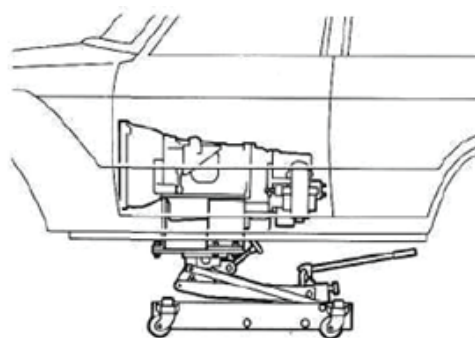
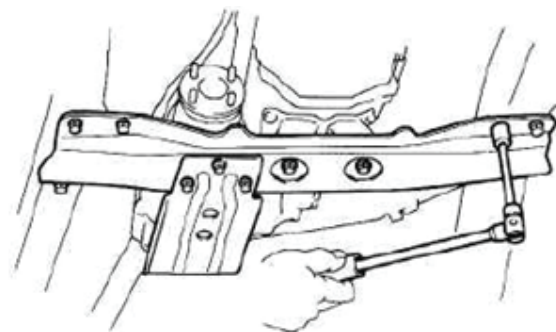

STEP 35

Reinstall the transfer case drain plug. Remove the fill plug and fill the transfer case with the API GL-5 SAE 75W-90 gear oil or the gear oil recommended in your Land Cruiser Owner's Manual. Reinstall the fill plug.

STEP 36

Install the Center Differential Lock Switch (switch not included) into your dashboard and connect to the switch to the factory wiring harness. There is already a receptacle for the switch in the factory wiring harness. Remove the plug and jumper wire from the receptacle and connect to the Center Differential Lock Switch. Discard the plug and jumper wire.

INSTALL INSTRUCTIONS (CONT'D.)



STEP 37

FJ80 manual locking hubs must be installed in place of the stock drive flanges (locking hubs not included). FJ80 models built after 1992 have longer stub shafts. Before installing the snap ring onto the stub shaft, measure end float and install a 6mm or 8mm spacer to prevent axle end float (spacers not included).

STEP 38

Verify all bolts have been reinstalled and torqued. Verify all wiring plugs and hoses have been reconnected. Take the vehicle for a short test drive and verify shift lights and speedometer function. After the transfer case cools, recheck the gear oil level.

OPERATION

To engage Low 4WD, turn the knob on the locking hub to "Lock" and move the transfer case shift lever to the 4WD low position. The Center Differential Lock button does not have to be on, as the transfer case will automatically lock as soon as the transfer case shift lever is put into the 4WD low position.

To engage High 4WD, turn the knob on the locking hub to "Lock" and turn the Center Differential Lock button on.

DO NOT engage the Center Differential Lock while the vehicle is moving. Doing so may damage the front output clutch hub or the center differential front drive.

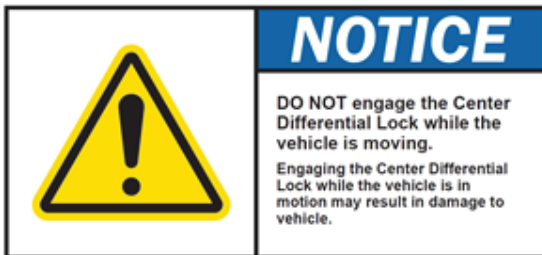

When the locking hubs are disengaged, the Anti-Lock Braking System (ABS) will be disabled and the ABS fault light will light up on your dashboard. This means that the braking system will function as a standard braking system (no ABS function). If ABS is required in certain driving conditions (e.g. wet or icy roads) you must engage the locking hubs.



INSTALL INSTRUCTIONS (CONT'D.)



REPLACEMENT PARTS

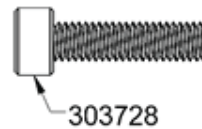
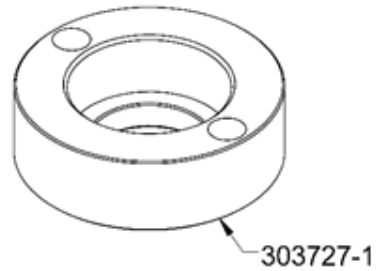
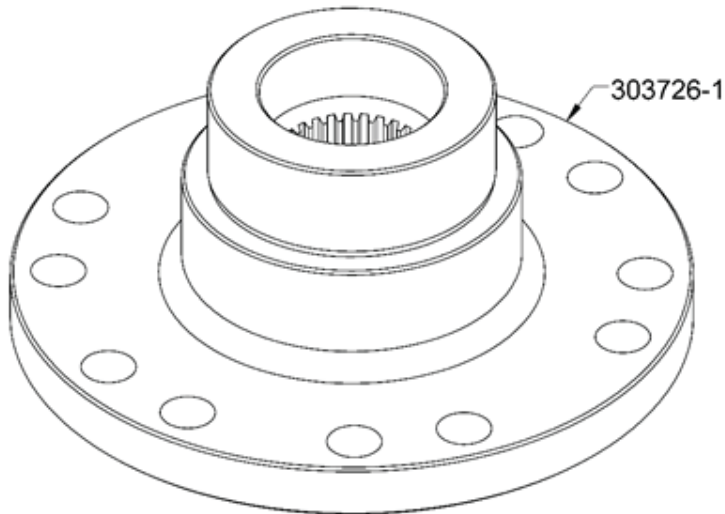

181004